

**SKB**

---

**TECHNICAL  
REPORT**

---

**93-22**

**Carbon transformations in deep granitic groundwater by attached bacterial populations characterized with 16S-rRNA gene sequencing technique and scanning electron microscopy**

Susanne Ekendahl, Johanna Arlinger, Fredrik Ståhl,  
Karsten Pedersen

Department of General and Marine Microbiology,  
University of Göteborg, Göteborg, Sweden

October 1993

---

**SVENSK KÄRNBRÄNSLEHANTERING AB**

*SWEDISH NUCLEAR FUEL AND WASTE MANAGEMENT CO*

BOX 5864 S-102 40 STOCKHOLM

TEL. 08-665 28 00 TELEX 13108 SKB S

TELEFAX 08-661 57 19

CARBON TRANSFORMATIONS IN DEEP GRANITIC GROUNDWATER BY  
ATTACHED BACTERIAL POPULATIONS CHARACTERIZED WITH 16S-rRNA  
GENE SEQUENCING TECHNIQUE AND SCANNING ELECTRON MICROSCOPY

Susanne Ekendahl, Johanna Arlinger, Fredrik Ståhl,  
Karsten Pedersen

Department of General and Marine Microbiology, University of  
Göteborg, Göteborg, Sweden

October 1993

This report concerns a study which was conducted  
for SKB. The conclusions and viewpoints presented  
in the report are those of the author(s) and do not  
necessarily coincide with those of the client.

Information on SKB technical reports from  
1977-1978 (TR 121), 1979 (TR 79-28), 1980 (TR 80-26),  
1981 (TR 81-17), 1982 (TR 82-28), 1983 (TR 83-77),  
1984 (TR 85-01), 1985 (TR 85-20), 1986 (TR 86-31),  
1987 (TR 87-33), 1988 (TR 88-32), 1989 (TR 89-40),  
1990 (TR 90-46), 1991 (TR 91-64) and 1992 (TR 92-46)  
is available through SKB.

**Carbon Transformations in Deep Granitic Groundwater by Attached Bacterial  
Populations Characterized with 16S-rRNA Gene Sequencing Technique and  
Scanning Electron Microscopy**

*Susanne Ekendahl, Johanna Arlinger, Fredrik Ståhl and Karsten Pedersen*

Department of General and Marine Microbiology  
University of Göteborg,  
Carl Skottsbergs gata 22, S-413 19 Göteborg, Sweden

October 1993

keywords: activity, bacteria, deep groundwater, diversity, identification,  
microbiology, respiration, scanning electron microscopy, viability, 16S-rRNA,

## ABSTRACT (ENGLISH)

This report presents molecular characterization of attached bacterial populations growing in slowly flowing ( $1-3 \text{ mm s}^{-1}$ ) artesian groundwater from deep crystalline bed-rock of the Stripa research mine, south central Sweden. The assimilation rates of  $\text{CO}_2$  and lactate, and the lactate respiration rates were also determined. The bacteria studied grew in anoxic, high pH, 9-10, and low redox artesian groundwater flowing up through tubings from two levels of a borehole designated V2, 812-820 m and 970-1240 m below ground.

Bacteria were allowed to attach to and grow on sterile microscope glass slides in laminar flow reactors connected to the flowing groundwater. Total numbers of bacteria were counted with acridine orange direct counts. The bacteria grew slowly with doubling times of 34 days for the 812-820 m population, 23 days for the 970-1240 m population in  $10^\circ\text{C}$  and 16 days in  $20^\circ\text{C}$ . Numbers of attached bacteria reached between  $10^6$  and  $10^7$  bacteria  $\text{cm}^{-2}$  after at most 160 days of exposure.

The glass slides were collected, the bacterial DNA was extracted and the 16S-rRNA genes amplified with PCR using primers matching universally conserved positions 519-536 and 1392-1405. The resulting PCR fragments were subsequently cloned and sequenced. The sequences were compared with each other and with 16S-rRNA sequences in the EMBL database.

Three major groups of bacteria were found. Signature bases placed them in the appropriate systematic groups. All belonged to the Proteobacterial groups beta and gamma. One group was found only at the 812-820 m level, where it constituted 63% of the sequenced clones, whereas the second group existed almost exclusively and constituted 83% of the sequenced clones at the 970-1240 m level. The third group was equally distributed between the levels. A few other bacteria were also found. None of the 16S-rRNA genes from the dominating bacteria resembled any of the other by more than 90% similarity, and none of them resembled anything in the database by more than 96%. Temperature did not seem to have any effect on species composition at the deeper level. SEM images showed rods appearing in microcolonies. The difference in population diversity between the two levels studied presumably reflect the different

environments. The earlier proposed presence of sulphate reducing bacteria could not be confirmed.

The CO<sub>2</sub> assimilation rates (as mole CO<sub>2</sub> cm<sup>-2</sup> h<sup>-1</sup>, using liquid scintillation techniques) increased with depth and temperature. The quotients calculated for inorganic/organic carbon utilization were between 0.07 and 0.25, indicating that autotrophy could not support the levels of growth observed and that heterotrophy was the dominating carbon transformation process for growth of the studied populations. The Stripa bacteria could further be seen not only to assimilate but also to catabolize lactate and release CO<sub>2</sub> from lactate, which adds to the indications of a heterotrophic dominance in the Stripa environment.

The influence these populations have on the carbon content in rock fractures is considered. The populations at the two levels of the borehole were different in physiology as well as in phylogeny and reflected the heterogeneity between the sampling levels. Available electron acceptors and possible present bacterial groups are discussed in relation to these results and the results from 16S-rRNA gene sequencing studies. The molecular techniques used and the combined studies of physiology, morphology and 16S-rRNA gene sequences in polyphasic taxonomy are also discussed.

## ABSTRACT (SWEDISH)

Bakteriepopulationer växande på ytor i sakta rinnande artesiskt grundvatten ( $1-3 \text{ mm s}^{-1}$ ) från djupt liggande kristallint berg under Stripa forskningsgruva karakteriserades med molekylärbiologiska metoder. Hastigheten för upptag av  $\text{CO}_2$  och laktat samt hastigheten varmed laktat respirerades till  $\text{CO}_2$  bestämdes också. Bakterierna växte i syrefritt grundvatten med ett högt pH, 9-10, och med en låg redoxpotential. Vattnet strömmar under artesiskt tryck upp genom rör från två nivåer i ett borrhål benämnt V2, från 812-820 m och 970-1240 m under markytan.

Bakterier i grundvattnet vifhäftade och tillväxte på sterila glasytor i laminära flödesreaktorer kopplade till det rinnande grundvattnet. Totalantalet bakterier bestämdes i mikroskop efter akridinorange-färgning. Bakterierna växte sakta med fördubblingstider på 34 dagar för 812-820 m populationen, 23 dagar för 970-1240 m vid  $10^\circ\text{C}$  och 16 dagar vid  $20^\circ\text{C}$ . Antalet växande vidhäftade bakterier blev mellan  $10^6$  och  $10^7$  bakterier  $\text{cm}^{-2}$  efter som mest 160 dagars exponering av ytorna för rinnande grundvatten.

Glasytorna samlades in och allt bakteriellt DNA på dem extraherades. 16S-rRNA genen amplifierades med PCR-teknik med hjälp av det universiella konservativa primerparet 519-536 och 1392-1405. Resulterande PCR-fragment klonades och sekvensades. De erhållna sekvenserna jämfördes med varandra och med andra 16S-rRNA sekvenser i EMBL:s databas.

Tre huvudgrupper av bakterier kunde identifieras. Signaturbaser placerade dem i korrekta systematiska grupper. Alla tillhörde proteobakteriernas beta och gamma grupper. En av grupperna återfanns bara på 812-820 m nivån där den utgjorde 63% av de sekvensade klonerna, medan en andra grupp med något undantag återfanns i 83% av klonerna på 1240 m nivån. Den tredje gruppen var lika fördelad på de båda nivåerna. Några få andra bakterier påträffades också. Ingen av de funna 16S-rRNA generna liknade någon av de andra med mer än 90% och ingen liknade något i databasen med mer än 96%. Temperaturskillnaden hade inte någon inverkan på

artfördelningen på den djupare nivån. SEM bilder visade mikrokolonier av stavar på båda nivåerna. Skillnaden i populationsdiversitet mellan de två nivåerna speglar fömodligen skilda tillväxtförhållanden. Den tidigare föreslagna förekomsten av sulfatreducerande bakterier kunde inte konfirmeras.

Upptagshastigheterna för CO<sub>2</sub> (som mole CO<sub>2</sub> cm<sup>-2</sup> h<sup>-1</sup>, uppmätt med hjälp av vätskeskintillations-teknik) ökade med ökande djup och temperatur. De beräknade kvoterna för oorganiskt/organsikt kolupptag varierade mellan 0.07 och 0.25, vilket tyder på att autotrofi inte kan förklara den observerade tillväxten utan att heterotrofi var den dominerande processen. Stripa-bakterierna observerades också katabolisera tillsatt laktat och frigjorde CO<sub>2</sub> från denna process vilket ytterligare stöder antagandet om en heterotrofi-dominans i Stripa-miljön.

De studerade bakterie-populationernas inverkan på kolinnehållet i grundvatten i berg diskuteras. Populationerna på de båda nivåerna var fysiologiskt och fylogenetiskt olika vilket speglar en heterogenitet mellan provtagningsnivåerna. Tillgängliga elektronacceptorer och troliga aktiva bakteriegrupper i djupt grundvatten diskuteras i förhållande till erhållna resultat. Utnyttjandet av molekylärbiologiska tekniker i kombination med studier av fysiologi, morfologi och 16S-rRNA-gen sekvenser i polyfasisk taxonomi diskuteras också.

## CONTENTS

	ABSTRACT (ENGLISH)	ii
	ABSTRACT (SWEDISH)	iv
	TABLE OF CONTENT	vi
1	INTRODUCTION	1
2	MATERIALS AND METHODS	5
	2.1 Description of study site	5
	2.2 Experimental set-up	5
	2.3 Water and gas analysis	6
	2.3.1 Water analysis	6
	2.3.2 Gas analysis	7
	2.4 Total numbers of unattached and attached bacteria	7
	2.5 SEM studies of attached bacteria	7
	2.6 Enrichment cultures	7
	2.7 Phylogenetic studies	8
	2.7.1 DNA extraction	8
	2.7.2 PCR amplification and purification of the product	9
	2.7.3 Cloning	10
	2.7.4 Double-stranded sequencing	11
	2.7.5 Sequence analysis	11
	2.7.6 Nucleotide sequence accession numbers	11
	2.7.7 Control for quantitative PCR, cloning and sequencing	12
	2.8 Assimilation of CO <sub>2</sub>	12
	2.9 Calculations of CO <sub>2</sub> assimilation/total cell carbon ratios	13
	2.10 Lactate assimilation and respiration	14
	2.11 Sulphate assimilation and reduction	14
3	RESULTS	17
	3.1 Chemistry of the groundwaters	17
	3.2 Growth and total numbers of bacteria	17
	3.3 SEM studies	17
	3.4 Enrichment cultures	18
	3.5 Grouping of clones	18



3.5.1	Level 812-820 m	18
3.5.2	Level 970-1240 m	18
3.5.3	Control for quantitative PCR , cloning and sequencing	19
3.6	Phylogenetic relationships	19
3.7	Assimilation of CO <sub>2</sub> , lactate assimilation and respiration	20
3.8	CO <sub>2</sub> assimilation/total cell carbon ratios	20
3.9	Sulphate assimilation and reduction	20
4	DISCUSSION	33
4.1	Heterogeneity between sampling levels	33
4.2	SEM studies	34
4.3	Enrichment studies	34
4.4	DNA techniques	35
4.4.1	DNA extraction	35
4.4.2	Amplifying genes with PCR	35
4.4.3	Cloning	36
4.4.4	Sequencing	37
4.4.5	Sequence analysis	37
4.5	Phylogeny	37
4.6	Comparison between the different populations	38
4.7	Studying deep groundwater bacteria	39
4.8	Electron acceptors and bacterial groups	39
4.9	Autotrophy or heterotrophy?	40
4.10	Carbon transformations in the studied groundwaters	41
5	ACKNOWLEDGEMENTS	43
6	REFERENCES	45

# 1 INTRODUCTION

Radioactive waste from nuclear power plants has to be processed and safely deposited in repositories. The present Swedish concept is to encapsulate the waste in steel-copper canisters and surround them with bentonite in crystalline bed-rock, 500 m below ground (SKB-91). During 1987, a research project on microbial processes in deep groundwater systems was initiated at the department of General and Marine Microbiology at the University of Göteborg. Our results (Pedersen and Ekendahl 1990, 1992a, 1992b) and those of others (Erlich 1990; Gold 1992; Pedersen 1993a; Stevens et al 1993) clearly demonstrate that microbes may be involved in many subterranean geochemical processes, such as diagenesis, weathering, precipitation, and in oxidation and reduction reactions of metals, carbon, nitrogen and sulphur - just as they are in most terranean environments. The aim of the project is to understand how subterranean bacteria interact with these processes during and after the construction of a nuclear waste repository, thereby reaching the safest possible disposal of high level nuclear waste. The project comprises several interacting microbial processes in groundwater that are important for the performance safety assessment of a repository. Bacteria are inevitably interacting with the carbon cycle, thereby affecting pH, redox potential and the organic content of the groundwater. The presence of sulphate reducing bacteria (Fontes et al 1989; Fritz 1989; Pedersen and Ekendahl 1990; Pedersen 1993b) can be precarious for canister corrosion through their production of hydrogen sulphide. Growth of bacteria on fracture surfaces and their participation in the formation of fracture minerals, weathering and radionuclide sorption to the rock may also be influential.

A basic requirement in the work with bacteria is good methods for enumeration and identification of different bacterial species and coherent bacterial groups. The classical way to study the diversity of bacterial communities is to inoculate different solid and liquid media with environmental samples and incubate at different temperatures and gas conditions. Growing bacteria can then be enumerated and classified according to their morphological, chemical, and physiological properties. The Bergey's Manual of Determinative Bacteriology (Holt 1984-89) describes an array of such procedures.

An obvious drawback with all culturing methods is that only so called cultivable bacteria can be studied. Usually only a minor part of all the observed bacteria can be successfully enriched and cultured (Ward et al 1992). Microbial biomass, community structure and nutritional status can instead be studied with biochemical methods as was done by Balkwill et al. (1988) and White et al. (1983) or with methods in molecular genetics (Stackebrandt and Goodfellow 1991). DNA from all present organisms can be isolated from environmental samples (Johnson 1991; Maniatis et al 1982; Marmur 1961), amplified with the Polymerase Chain Reaction, PCR (Olsen et al 1986; Pace et al 1986; Steffen and Atlas 1991), sequenced (Ludwig 1991) and compared with DNA-sequences of known bacterial species (Olsen et al 1991). Most such work this far has been performed on the 16S-rRNA subunit of the bacterial ribosome, which has been found to be very suitable for identification (Amann et al 1991; Giovannoni et al 1990, Weller and Ward 1989; Woese 1987). These methods are now rapidly becoming standard protocols for studies of microbial ecosystems.

The deep subterranean environment is a relatively new area for microbiological research. The number of papers dealing with the deep groundwaters has increased during the last ten years. Groundwaters are often nutrient limited and offer more or less extreme conditions for life, yet bacteria have been found deep down below the ground surface (Pedersen 1993a). They catch scientific attention for several reasons such as drinking water contamination problems, toxic waste dumps and the storage of nuclear waste in the deep underground (Pedersen 1993b; Pedersen and Albinsson 1992; West et al 1982, 1985).

The deep granitic rock with groundwater, fractures and minerals has been suggested as a suitable place for the storage of high level nuclear waste in Sweden, where this kind of bed-rock is very common. A typical such granitic rock formation lies around the former iron ore research mine Stripa in south central Sweden. The iron ore consisted of a quartz-banded haematite in a lepatite formation and was mined out in 1976 (Nordstrom et al 1985). We have in earlier studies observed that bacteria existed down to 1240 m below ground in a borehole in this mine (Pedersen and Ekendahl 1992a.) We found active bacteria in the groundwater that assimilated carbon dioxide and thus had an autotrophic potential for *in situ* production of organic carbon. They incorporated introduced formate, glucose, leucine, and especially the incorporation of lactate was high, demonstrating a heterotrophic potential. Bacteria attached to glass surfaces were more active than unattached bacteria in the water.

In this study we have used the 16S-rRNA gene sequencing technique to characterize the attached Stripa populations. Results from enrichment cultures of these bacteria and studies of the populations with scanning electron microscopy are also reported. One aim was to identify dominating bacterial species or groups in the studied populations. The overall distribution of bacteria and the dominating groups at each of two levels of the selected borehole are described. The use of 16S-rRNA gene

sequencing, in combination with other microbiological techniques for the characterization of environmental samples is discussed. The rates of carbon dioxide and lactate assimilation, lactate respiration and biofilm development were compared both within and between the studied populations. Attempts were also made to assay if sulphate reduction was performed by the attached bacteria. Possible effects of attached bacterial populations on the carbon cycle in groundwater from deep crystalline bed-rock are discussed, as well as possible electron acceptors and bacterial groups.

## 2 MATERIALS AND METHODS

### 2.1 DESCRIPTION OF STUDY SITE

This study was performed in the Stripa research mine in Guldsmedshyttan, Västmanland, Sweden. The mine contained iron ore, a quartz-banded haematite occurring in a lepatite formation, which was mined out in 1976. The mine has been used for underground research since then, both for national and international (OECD/NEA) studies. Countries that participated in the international Stripa research project were Canada, Finland, France, Great Britain, Japan, Spain, Sweden, and the United States of America. The research mine was closed in 1991.

### 2.2 EXPERIMENTAL SET-UP

The borehole V2 (76 mm wide) was drilled subvertically through medium-grained granite adjacent to the lepatite from a mine drift 410 m below ground to 860 m in 1977 and continued to 1240 m in 1981. The borehole had an average of about 2 fractures per meter of rock. The studied flowing groundwater came from two levels of this borehole, 812-820 m and 970-1240 m. The levels were closed off with packers made of inflatable 76 mm rubber tubes. The artesian water from these levels has been continually flowing up to the drift through 6 mm teflon tubings since 1990 and its chemical composition has been well characterized (Nordstrom et al 1985). Laminar flow reactors (Pedersen 1982; Pedersen et al 1986) were connected to the slowly flowing groundwaters at flows of approximately  $1 \times 10^{-3} \text{ m sec}^{-1}$ , as shown in Fig. 2-1. Each flow reactor contained 12+24 parallel hydrophilic microscope glass slides, 60x24x1 and 40x24x1 mm respectively, heated in a muffle furnace at 475°C for 4 h. The waters were chilled to 10°C when flowing through the tubings up to the drift. The 970-1240 m groundwater was re-heated to 20°C in a hut in the drift to imitate the *in situ* temperature in the borehole (Fig. 2-1). The flowing waters

were collected from sterile 5 l glass bottles connected to the laminar flow reactors. All water used for measurements and incubations was taken from these bottles if nothing else is mentioned.

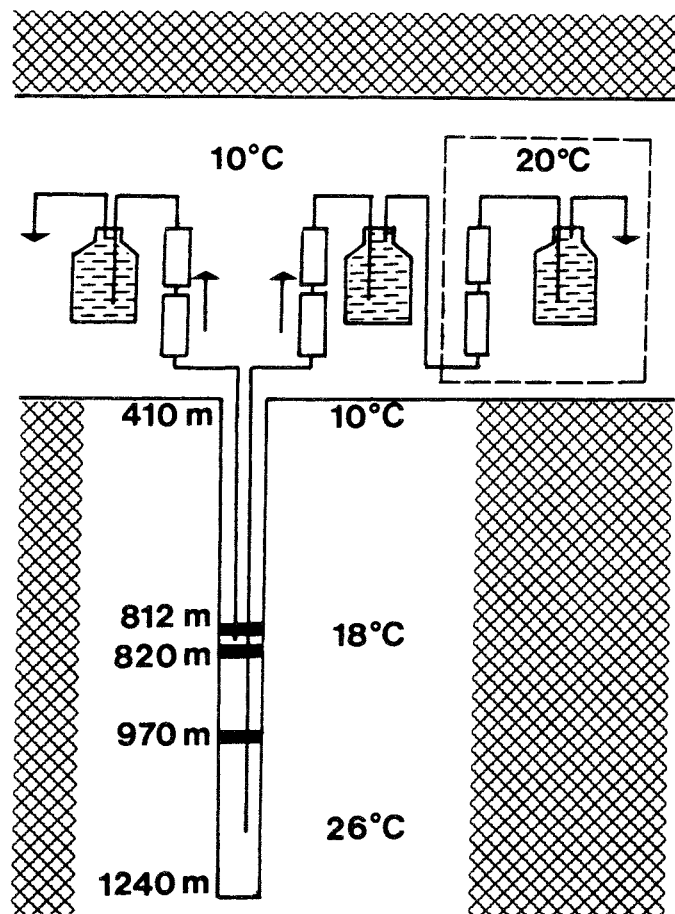

Figure 2-1 Experimental set-up with laminar flow reactors connected to flowing groundwater from the Stripa borehole V2.

## 2.3 WATER AND GAS ANALYSIS

### 2.3.1 Water analysis

The pH and the  $E_h$  were measured *in situ* in the mine with a PHM Autocal pH meter (Radiometer), a GK2421C combined pH electrode and redox electrode PK1401. Sulphate was measured turbidometrically with  $BaCl_2$  (Franson 1985), sulphide with a iodometric method (Franson 1985) and the TIC contents were measured with a coulometer (Model 5011  $CO_2$  Coulometer) (Huffman 1977). These procedures were repeated at a 30 day interval.

### 2.3.2 Gas analysis

Gas pipettes (100 ml) were connected to the flowing groundwaters, left overnight and closed. The dissolved gases of the waters were extracted by degassing the samples at  $<40$  Pa whereafter the total gas volume was collected in a burette fitted with a septum by step-wise pumping with mercury and compressed air. The gas composition was analysed with a Perkin Elmer gas chromatograph supplied with two columns [Porapak N 80-100 mesh 4m + 1/8" (0.32 cm) and Molesieve 5A 60-80 mesh 2' (61 cm) + 1/8" (0.32 cm)], a thermal conductivity detector and a flame ionisation detector. Carbon monoxide and carbon dioxide were converted to methane before detection. The carrier gas used was argon except for the hydrogen analysis when helium was used. This procedure was repeated at a 30 day interval.

Oxygen was measured as follows. Winkler bottles for each level and temperature were filled with water under nitrogen. The bottles were stored at  $+4^{\circ}\text{C}$  and a modified form of the common Winkler method was used for the analysis (Carritt and Carpenter 1972).

## 2.4 TOTAL NUMBERS OF UNATTACHED AND ATTACHED BACTERIA

Acridine orange stained direct counts (AODC) were used to determine the total numbers of unattached bacteria, as described earlier (Pedersen and Ekendahl 1990). Groundwater bacteria were allowed to attach and grow on the glass slides in the laminar flow reactors for up to 161 days for the 812-820 m level (January to June 1991) and 90 days for the 970-1240 m level (April to June 1991). The bacteria were stained in acridine orange, rinsed with distilled water and the total number of cells was counted.

## 2.5 SEM STUDIES OF ATTACHED BACTERIA

Microscope slides with attached bacteria were sampled and immersed in groundwater as above, fixed in glutaraldehyde, dehydrated with alcohol-acetone, critical point dried, sputtered with gold-palladium and observed in a Zeiss DSM 940 scanning electron microscope (SEM).

## 2.6 ENRICHMENT CULTURES

Sterile 100 ml serum bottles were provided with a medium of 0.5 ml 3.5 M sodium lactate, 10 ml 350 mM sodium sulphate, 5 mg sodium

dithionite, and with solutions of 60  $\mu$ l trace elements, 60  $\mu$ l selenite and tungstate, 30  $\mu$ l mixed vitamins and 60  $\mu$ l vitamin B<sub>12</sub> described elsewhere (Pedersen and Ekendahl 1990). Ten bottles for each level and temperature were inoculated with 50 ml of the sterile filtered alkaline groundwater under nitrogen. Sterile wooden sticks were used to rub attached bacteria off slides from the reactors and immediately put into the bottles. The bottles were closed with butyl rubber stoppers and stored at room temperature. Sterile glass beads (diameter 5 mm) were added to some of the bottles to increase the surface/volume ratio for eventually attached growth.

At a subsequent occasion, the same type of enrichment cultures were made, but this time 10 ml of either a borax-NaOH buffer (pH 10) or a carbonate buffer (pH 10) was added to each bottle to keep pH constant. Also, 0.1 to 0.2 ml Na<sub>2</sub>S (0.37 M) was added to keep redox low and stable.

In another set of enrichments, a medium consisting of 300 ml de-ionized water, 9 ml sodium lactate, 60 ml sodium sulphate, solutions of 0.9 ml trace elements and 0.9 ml selenite and tungstate was adjusted to pH 10 and autoclaved. Concentrations were the same as above. The medium was added in 5 ml portions to each of 30 sterile nitrogen-filled Hungate tubes, to which 0.15 g agar (hochrein) was added and mixed at +60°C. The tubes were closed with butyl rubber stoppers and cooled. In the mine the agar medium was melted and the tubes then heated in a +40°C water bath. Ten ml of flowing groundwater from 812-820 m were added to some tubes for culturing bacteria from the water phase. Into other tubes, the groundwater was Dynagard-filtered under nitrogen and pieces of 20 mm glass slides from a 812-820 m reactor were subsequently put into the agar of these tubes to culture attached bacteria. The tubes were cooled and incubated at room temperature in the dark.

## 2.7 PHYLOGENETIC STUDIES

Slides from the laminar flow reactors were sampled after 161 and 71 days, respectively, immersed in 0.22  $\mu$ m filtered groundwater, transported on ice to the laboratory where the groundwater was decanted from the slides, subsequently stored in at -80°C until DNA extraction. The DNA from the attached *Stripa* populations was subsequently extracted, the 16S-rRNA genes amplified with the PCR (Polymerase Chain Reaction), cloned and sequenced. The sequences of the *Stripa* bacteria were compared to other 16S-rRNA sequences of known bacteria available in the European Molecular Biology Laboratories (EMBL) database.

### 2.7.1 DNA extraction



Our protocol on DNA extraction was based on procedures described by Marmur (1961) and Wallace (1987), but was slightly modified. Glass slides, 40x24 mm, from the freezer were thawed and the surrounding groundwater decanted. Each glass was crushed, put in 760  $\mu$ l of 20 mM Tris-HCl, pH 8.0; 20 mM EDTA; 0.35 M sucrose and incubated with 2 mg/ml lysozyme (Sigma) at 37°C for 1 h to destroy cell walls. Thereafter, the attached cells were lysed by adding 40  $\mu$ l 20% SDS and the proteins digested with 250  $\mu$ g/ml of proteinase K (Sigma) during an additional incubation at 60°C for 1 h. The DNA was extracted from 400  $\mu$ l of the cell lysate solution with an equal volume of phenol:chloroform:isoamyl alcohol (25:24:1), followed by one extraction with chloroform:isoamyl alcohol (chisam, 24:1) so that no cell debris was visible. Finally the chisam was washed with TE buffer (10 mM Tris-HCl, 1 mM EDTA, pH 8.0). The DNA was precipitated with 1/3 volume of 10 M  $\text{NH}_4\text{Ac}$  (final conc. 2.5 M) and 2.5 volumes of 99% ethanol. To ensure complete recovery, 50  $\mu$ g tRNA was added as a carrier. The precipitate was washed with 100  $\mu$ l 70% ethanol (v/v) and dried in vacuum for 30 s, dissolved in TE buffer and stored at -20°C. This procedure was repeated once for each borehole level and temperature.

To get a representative material, all cells on the glass slides must be disrupted in the initial lysis steps. The degree of this cell disruption was measured by staining the slides with acridine orange after lysis as described for total direct counts (Pedersen and Ekendahl 1990). They were inspected for potential unlysed cells under blue light (390 to 490 nm) in an epifluorescence microscope (Zeiss, filter 515 nm) at 1,250 times enlargement. No cells were detected in these stainings which indicate a complete cell lysis. Additional control experiments with lysis of *Escherichia coli*, *Desulfomicrobium baculatum* and *Bacillus megaterium* in cell suspensions showed that 90-95% of the cells were lysed with this method.

### 2.7.2 PCR amplification and purification of the product

One  $\mu$ l of the extracted DNA solution was sufficient to amplify the 16S-rRNA region with the PCR (Prescott et al 1993). The DNA was added to a mixture of 10  $\mu$ l of 10xPCR buffer (Stratagene), 0.2 mM of each nucleotide triphosphate, 0.25  $\mu$ M of each primer and double distilled water to a final volume of 100  $\mu$ l. The samples were first treated with 10 mg/ml of RNase A (Sigma) for 15 min at 37°C and then incubated at 95°C for 5 min, before addition of 1  $\mu$ l Pfu DNA polymerase (Stratagene) and coating with 100  $\mu$ l mineral oil (Sigma). A total of 30 cycles were performed at 95°C (30 s), 55°C (1 min), 72°C (2 min) followed by a final incubation at 72°C for 10 min.

The 5' and 3' primers used matched the universally conserved positions 519-536 and 1392-1405, *E-coli* Brosius numbering (Brosius et al 1978). These were chosen to ensure that both eubacterial, archaebacterial and eventually eucaryotic species could be amplified. To facilitate cloning, a

SacII restriction enzyme site was synthesized at the 5' end of the 1405-1392 primer, by adding six bases to the conservative sequence (Table 2-1). The 519-536 primer sequence already contains a SacII site, why this sequence was kept unchanged except for two bases added at the 5' end to make both primers equal in size and purine/pyrimidine composition.

The amplification products were purified with the QIAEX agarose extraction kit (Qiagen) following the specification of the manufacturer, and were finally diluted in 20  $\mu$ l double distilled water and stored at -20°C.

Table 2-1 Oligonucleotides used in DNA sequencing and positions to which they bind in the 16S-rRNA gene (*E. coli* numbering). The two oligonucleotides marked with an asterisk (\*) were also used as primers in the PCR reaction. The bold characters mark SacII restriction enzyme sites in these two primers, whereas the underlined sequences represent additions to the original "universal" sequences.

Position of binding	Sequence of primer
519r - 536r*	5' <u>CGCAGCAGCCGCGGTAATAC</u> 3'
686r - 705r	5'GTAGCAGTGAAATGCGTAGA3'
705f - 686f	5'TCTACGCATTTCACTGCTAC3'
907r - 926r	5'AAACTCAAATGAATTGACGG3'
926f - 907f	5'CCGTCAATTCATTTGAGTTT3'
1405f - 1392f*	5' <u>ATACCGCGGGCGGTGTGTAC</u> 3'

### 2.7.3 Cloning

The purified samples were digested with SacII (Boehringer Mannheim) in a solution consisting of 16-19  $\mu$ l (100-350 ng) DNA, 10% 10xRM buffer, 2-4  $\mu$ l Sac II and double distilled water to a final volume of 50 $\mu$ l. The incubation was performed at 37°C for 2 h and stopped at 65°C for 15 min. The samples were purified once more with QIAEX and thereafter the DNA was ligated with a pBluescript SK- vector (Stratagene) using standard methods (Maniatis et al 1982). The vector was also SacII digested and calf intestine phosphatase (CIP, Boehringer Mannheim) treated to

prevent self ligation. Shortly, the molar ratio between DNA insert and the vector was 1:1 or 2:1. The ligation mixture consisted of 1  $\mu$ l (100 ng) PSK-, 1 or 2  $\mu$ l (30-65 ng) insert, 0.5  $\mu$ l 10 x RM buffer, 0.3  $\mu$ l T4 DNA ligase (Boehringer Mannheim) and double distilled water to a final volume of 5  $\mu$ l. The incubation was performed overnight at +4°C.

The ligated products were transformed into 10% glycerol washed *Escherichia coli* (XL1blue, Stratagene) by electroporation (BioRad). From each transformation, 50 or 100  $\mu$ l was spread on Luria Broth agar plates which contained 1/500 volume ampicillin (25 mg/ml) and had been coated with 60  $\mu$ l 2% X-Gal and 40  $\mu$ l 100 mM IPTG 30 min before spreading. They were incubated overnight at 37°C in the dark. From each DNA extraction, a total of 30 white colonies containing the insert was randomly picked out and numbered 1 to 30. They were grown in 5 ml LB + ampicillin solution overnight at 37°C. From each culture 0.5 ml was suspended in 0.5 ml of conc. glycerol and stored at -80°C. Every third clone (12 of every 30 clones), a total of 72 clones, were picked out for subsequent sequencing. The recombinant plasmids were extracted from the bacteria with the Magic miniprep kit (Promega).

#### 2.7.4 Double-stranded sequencing

The sequencing was made using the double-strand sequencing protocol of the Multi-Pol DNA sequencing system (Clontech) and standard procedures were followed. Before the actual sequencing reactions, 1-4  $\mu$ g of the DNA was denatured with 2 M NaOH, precipitated with 3 M NaAc and 99% ethanol and washed with 70% ethanol. All clones were sequenced using the primer 907r (Table 2-1), run on 6% polyacrylamide gels and exposed to X-ray film for 3 days. The 72 sequences were compared with each other by reading directly on the films and divided into groups. Clones that were identical were put in the same group. One clone from each dominating group was fully sequenced and several different internal primers were used in these reactions, as specified in Table 2-1.

#### 2.7.5 Sequence analysis

Multiple alignments and comparison with 16S rRNA genes of other organisms were made using the Genetic Computer Group (GCG) sequencing analysis and the European Molecular Biology Laboratories (EMBL) database. The sequences were also compared with signature bases in Woese's article "Bacterial evolution" (Woese 1987) to place them into systematic groups.

#### 2.7.6 Nucleotide sequence accession numbers

The nucleotide sequences of the bacteria chosen from the three dominating groups I, II and III are deposited in EMBL and GENBANK databases under accession numbers L20810, L20811 and L20812 respectively.

### 2.7.7 Control for quantitative PCR, cloning and sequencing

Mixtures of typical groundwater bacteria, 4 parts *Desulfomicrobium baculatum* and 1 part *Gallionella ferruginea* at  $5 \times 10^4$  and  $10^6$  cells  $\text{ml}^{-1}$  and of 1 part each of *Bacillus megaterium*, *Desulfomicrobium baculatum* and *Gallionella ferruginea* at  $10^4$  and  $10^6$  cells  $\text{ml}^{-1}$  were extracted PCR-treated, cloned and sequenced as above.

## 2.8 ASSIMILATION OF $\text{CO}_2$

Groundwater, sampled from the two borehole levels, was filtered in 20 ml volumes under nitrogen atmosphere through Dynagard hollow fibres syringe filters (pore size  $0.2 \mu\text{m}$ ), into sterile 50 ml polypropylene centrifuge tubes with lids (Nunc). Microscope slides from the laminar flow reactors were transferred under nitrogen atmosphere to tubes with corresponding filtered groundwater, one slide per tube. Labelled carbonate,  $\text{Na}_2^{14}\text{CO}_3$  (Amersham Sweden AB), was subsequently added in 1 ml oxygen-free portions to assay the  $\text{CO}_2$  assimilation of the populations studied. The specific activity used was  $2.06 \times 10^9$  Bq  $\text{mmol}^{-1}$  and the final concentration of  $^{14}\text{C}$  in the tubes was  $20 \mu\text{M}$ . One ml of an unlabelled oxygen-free lactate solution (pH 10, final concentration  $10 \mu\text{M}$ ) was added to one set-up of tubes. The microscope slides were incubated horizontally for 1 to 4 h at 10 or  $20^\circ\text{C}$  on a slow shake, after which formalin was added to a final concentration of 2%. Controls for abiotic adsorption of the labelled carbonate were achieved by addition of formalin (2%) to clean sterile and sample slides together with the labelled compound at sampling and processed as the other samples. Control counts were subtracted from sample counts. Subsequently, each slide was then rinsed with a surface rinse (Pedersen et al 1986) containing distilled water with 1% NaCl (pH 3.0), cut into 4 pieces (Pedersen and Ekendahl 1992a), placed in 20 ml scintillation cocktail (Ready Safe, Beckman) and counted in a Beckman LS 3801 scintillation counter.

Doubling the  $^{14}\text{C}$  concentration from 20 to  $40 \mu\text{M}$  resulted in a corresponding increase in  $^{14}\text{C}$  assimilation, but the uptake rate was not affected by this concentration change. The isotope contents of the liquid in the tubes were measured just before the addition of formalin by taking out 0.1 ml to 10 ml Ready Safe. The total radioactivity in each tube was calculated as the sum of the radioactivity in the liquid and on the glass slide. The sums were equal to the added amounts and had a standard deviation of between 2.4 and 6.2% of the mean value with  $20 \mu\text{M}$  and of 13% with  $40 \mu\text{M}$ , showing that the added isotope did not disappear during the experiment and that the tubes had similar  $^{14}\text{C}$ -activities.

During sampling, pH and  $E_h$  were measured *in situ* in series parallel with the assimilation experiments to check that incubation conditions were constant. Tubes were prepared without slides but with unlabelled compounds added to the filtered groundwaters. A PHM Autocal pH meter (Radiometer), a GK 2421C combined pH electrode and a PK 1401 redox electrode was used. pH in the tubes decreased somewhat (maximum 0.6 units) during incubation. The redox potentials were stable. Temperature had no detectable influence on either pH or  $E_h$ .

## 2.9 CALCULATIONS OF CO<sub>2</sub> ASSIMILATION/TOTAL CELL CARBON RATIOS

The quotient between carbon dioxide assimilated and carbon demanded for growth, here called "autotrophy", was calculated as follows. The carbon content of mean-sized bacteria was calculated from their volumes. This was done by measuring the length and width of the bacteria with a ruler directly on slide projections with biofilm bacteria from the reactors. Two slides from each level and temperature was used, and 50 cells were measured on each of them. The volume per bacterium was calculated according to Grigorova and Norris (1990), where

$$V = (\pi/4) \cdot D^2 \cdot (L-D/3) \quad (1)$$

and  $V$  = volume,  $D$  = width and  $L$  = length.

A conversion factor for the calculation of the carbon content of a mean-sized bacterium was determined by multiplying a 30% dry weight of a cell (Neidhardt et al 1990), a 50% dry weight carbon content (Neidhardt et al 1990; Stainer et al 1990) and an assumed bacterial density similar to water of  $1 \times 10^{-12} \text{ g } \mu\text{m}^{-3}$ . The conversion factor  $F$  becomes  $1.5 \times 10^{-13} \text{ g C } \mu\text{m}^{-3}$  or  $0.125 \times 10^{-13} \text{ mole C } \mu\text{m}^{-3}$ . For comparison, Grigorova and Norris (1990) compiled several direct biomass estimations where a majority of the investigators have used epifluorescence microscopy for cell volume estimates and CHN analyses for cell carbon measurement. These conversion factors ranged from  $0.5 \times 10^{-13}$  to  $6.5 \times 10^{-13} \text{ g C } \mu\text{m}^{-3}$  and showed large coefficients of variation. Grigorova and Norris recommend the average conversion factor  $3.1 \times 10^{-13} \text{ g C } \mu\text{m}^{-3}$  bacteria.

The measured amount of carbon assimilated per bacterium at a density of  $1.8 \times 10^6 \text{ cells cm}^{-2}$  was divided with the carbon demanded for growth for one bacterium, taking into consideration the doubling time of the population. This "autotrophy" quotient shows the autotrophic potential of the population. The following formulas were used:

$$Q = A/B \quad (2)$$

where  $Q$  = the "autotrophy" quotient,  $A$  = assimilated carbon as mole C/bacterium and hour (results taken from Table 5) and  $B$  = carbon demanded for growth.

$$B = (F \cdot V \cdot k/24)/\log 2 \quad (3)$$

where  $F$  = conversion factor, and  $V$  = cell volume, and  $k$  = bacterial growth rate constant ( $\text{day}^{-1}$ ), achieved from linear regressions during the growth period from day 27 onwards.

## 2.10 LACTATE ASSIMILATION AND RESPIRATION

Lactate assimilation of attached bacteria was measured with the same tube set-up and methods as in the  $\text{CO}_2$  incubations, *i.e.* with 20 ml filtered groundwater and one glass slide in each tube. The tubes contained 1 ml of 1.0 or 2.5  $\mu\text{M}$  U- $^{14}\text{C}$ -lactate, specific activity  $5.69 \times 10^9$  Bq  $\text{mmol}^{-1}$ , were closed with rubber stoppers and incubated as described before. Respiration was measured as shown in Fig. 2-2. To each tube with labelled lactate 0.8 ml 0.3 M HCl was added after incubation. The tubes were shaken,  $\text{N}_2$  gas was bubbled through for 15 minutes and the released  $^{14}\text{CO}_2$  originating from the respired lactate was precipitated in 20 ml serum bottles preceded by an empty safety bottle. The three traps each contained 10 ml 1.9M KOH. Two subsamples of 0.1 and 1 ml were taken from each trap and put into glass vials with 10 ml scintillation cocktail (Hionic Fluor, Packard). The radioactivity was measured as DPM in the scintillation counter. Background controls were made with 0.1 and 1 ml of the KOH solution in Hionic Fluor and subtracted from sample counts. Then the slides were cut as described for  $\text{CO}_2$  assimilation. Also, duplicate controls showed that lactate did not release  $\text{CO}_2$  when HCl was added. The closed tubes did not release any  $\text{CO}_2$ . The total isotope content in each tube (radioactivity in the liquid and on the glass slide), was measured after the respiration measurements. The values had a standard deviation of between 3.5 and 8.4% of the mean and showed that the added concentration in the tubes were reproducible and that the isotope did not disappear during the experiment.

## 2.11 SULPHATE ASSIMILATION AND REDUCTION

Sulphate assimilation and reduction to sulphide were measured with a tube set-up similar as for lactate respiration (20 ml filtered groundwater, one slide and 1 ml oxygen-free isotope solution per tube) and the methods used for lactate assimilation and respiration measurements, see Fig. 2-2, but with the following changes: The isotope was  $\text{Na}_2^{35}\text{SO}_4$  with a specific activity of  $4 \times 10^7$  MBq  $\text{mmol}^{-1}$ , giving a final concentration of  $^{35}\text{S}$  in the

tubes of 2.8 or 4.2 nM. The tubes also contained 1 ml of unlabelled lactate to a final concentration of  $10 \mu\text{M}$ . The sulphate reduction was stopped by precipitating  $\text{H}_2\text{S}$  with 5 ml 20% zinc acetate (Fossing and Jørgensen 1989) and the tubes were immediately frozen on dry ice. Acidification (giving a pH below 2) was made with 1.5 ml 5 M HCl. The traps contained 10 ml 5% zinc acetate + 0.1% acetic acid. Nitrogen was bubbled through for 30 minutes. From each of three traps 3 ml subsamples were mixed with 15 ml Hionic Flour. Testing the method with sulphate reducers previously isolated from another groundwater (Pedersen and Ekendahl 1990) and subcultured in the laboratory showed that the method worked very well.

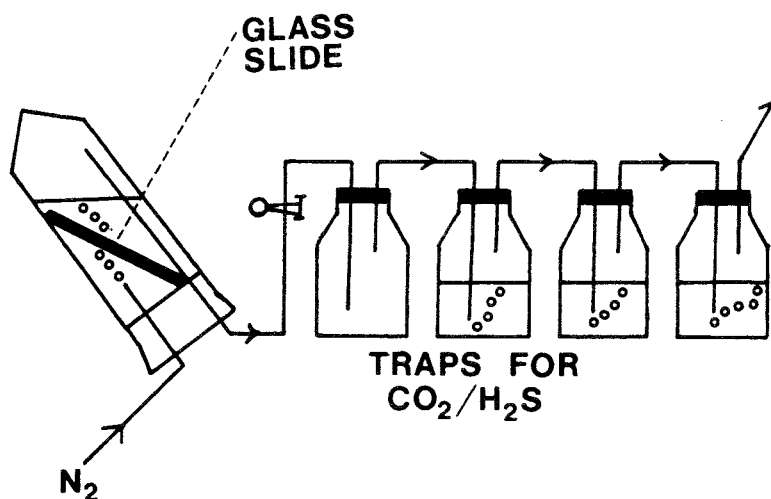

Figure 2-2 Experimental set-up for measuring lactate respiration and sulphate reduction.

## 3 RESULTS

### 3.1 CHEMISTRY OF THE GROUNDWATERS

The results from the water and gas analysis are shown in Tables 3-1 and 3-2. These data differ between the sampling depths and thereby indicate that the groundwaters were obtained from fracture systems with no close hydraulic connections.

### 3.2 GROWTH AND TOTAL NUMBER OF BACTERIA

The total numbers of unattached bacteria can be seen in Table 3-3. It shows that there were more bacteria present at the deeper level, and also that the variation in the numbers of bacteria was low between the sampling occasions. Fig. 3-2 shows total numbers of bacteria on slides after attachment and growth for up to 161 days. The bacteria appeared in micro-colonies on the surfaces which indicates growth. This is shown on the SEM images (Fig 3-1). The total numbers after 43 days were between  $10^6$  and  $10^7$  bacteria  $\text{cm}^{-2}$ , as compared to total numbers in the liquid phase, which were in the range of  $10^4$   $\text{ml}^{-1}$  for 812-820 m and  $10^5$   $\text{ml}^{-1}$  for 970-1240 m. Linear regression from the 27th day onward gives doubling times for the populations, and these are shown in Table 3-9.

### 3.3 SEM STUDIES

Fig. 3-1a and 3-1b show microscope slides which have been exposed to flowing groundwater from 812-820 m depth ( $2.8 \times 10^{-3}$   $\text{m sec}^{-1}$ ) for 161 days. A thin film that dried during SEM preparations (Fig. 1h) covered colonies of short rods, 1-2.5  $\mu\text{m}$  (average 2.0  $\mu\text{m}$ ). Some AODC images from this depth showed a few bacteria with an outer morphology



resembling *Planctomycetes* (not shown). Occasionally, stalked bacteria resembling *Caulobacter* could be observed (Fig. 3-1g). Fig. 3-1c and 3-1d show bacteria from 970-1240 m, 10°C, after 71 days of exposure. The rods were 1.5-2.5 (average 2.2)  $\mu\text{m}$  long and appeared single or in colonies. Fig. 3-1e and 3-1f show bacteria from the same interval after 71 days, but exposed to 20°C. These rods had an average length of 2.4  $\mu\text{m}$  but were sometimes filamental (more than 5  $\mu\text{m}$  long). They appeared in colonies and thin, 100 nm, threads were present together with the bacteria.

### 3.4 ENRICHMENT CULTURES

The attempts to cultivate the Stripa bacteria in serum bottles and agarshakes were all unsuccessful. Two morphological types of cells could be seen when subsamples from 970-1240 m, 20°C, were stained with acridine orange and studied with epifluorescence microscopy. Some were long thin rods and others were oval in shape. The bacteria in one bottle grew to 5 times their original numbers during 9 days, but did not grow any further after that.

### 3.5 GROUPING OF CLONES

The examined clones clustered into three major groups called I, II, and III, as seen in Table 3-5. Clones that were identical were placed in the same group and clones that differed from the major groups, appearing only once, were regarded as single observations. None of the clones among the single observations were identical, but some were closely related to the dominating groups, differing by only a few bases.

#### 3.5.1 Level 812-820 m

Almost two thirds of the clones from this level belonged to group I (Table 3-5). Two clones belonged to group II, and the remaining four clones (17%) clustered in group III. Three clones were single observations. The ratio between the two extractions is close to 1:1 and therefore comparable.

#### 3.5.2 Level 970-1240 m

Group II dominated this level at 10°C. As much as 83% of the clones were of this type. No clones from group I was found and only one clone belonged to group III.

At 20°C more than half, 13 clones or 54%, belonged to group II, none to group I and four clones belonged to group III. Four of the 7 clones that

were single observations did not show much resemblance to any other sequences. Since these four clones were found only in the first DNA extraction and two of them were related to eucaryotes, one of them showing 100% similarity to human chromosomal DNA, we suspected that this extraction was contaminated in the laboratory. These four clones are therefore not considered further.

The ratio of clones between the two extractions was close to 1:1 at both 10 and 20°C. The distribution of clones between the two temperatures at this level is also comparable if the four contaminants are excluded. Due to their exclusion, the percentage of the group I bacteria at 20°C rises to 65%, group II to 20% and group III decreases to 15% of the total number of clones at 20°C.

### 3.5.3 Control for quantitative PCR, cloning and sequencing

Applying this technique on equal sized bacteria (mixture 1), the sequences came out in the same proportions as in the start mixture (Table 3-4). When the 24 times larger *B megaterium* was included (mixture 2), its DNA dominated the result.

## 3.6 PHYLOGENETIC RELATIONSHIPS

The fully sequenced clone from group I compared with signature bases (Woese 1987) placed it among the beta group of the Proteobacteria, as shown in Table 3-6. This group was found only at the 812-820 m level and the highest percentages of similarity was found with the bacteria *Pseudomonas solanaceum*, 91.7 % and *Zoogloea ramigera*, 91.2 %.

Except for two clones from the 812-820 m level, group II was found to exist and dominate at the 970-1240 m level, at both temperatures. This group falls into the beta-1 group of the Proteobacteria and the highest percentages of similarity was found with *Pseudomonas testosteroni*, 95.9% and *Brachymonas denitrificans*, 94.9%.

Group III was found at both levels in comparable frequencies. This group belongs to the gamma group of the Proteobacteria and showed highest similarities with *Acinetobacter calcoaceticus*, 96.1 % and *Pseudomonas aeruginosa*, 87.7 %.

Comparing the whole bacterial sequences from the three major groups with each other (Table 3-7) showed that the highest percent of similarity (88.4%) was found between groups I and II. Comparisons between the most related bacteria for each group are also included in this table.

### 3.7 ASSIMILATION OF CO<sub>2</sub>, LACTATE ASSIMILATION AND RESPIRATION

The assimilation of CO<sub>2</sub>, lactate and respiration of the added lactate to CO<sub>2</sub> was plotted against the incubation time (4 h, not shown). A detailed description of the calculation criteria is given by Pedersen & Ekendahl (1992b). Briefly, assuming that the assimilation was correlated to time, only data that in a linear regression had a correlation coefficient larger than 0.7 and a significance level larger than 95% were further examined. We assumed the slope of each line to reveal the *in situ* rate of assimilation and respiration, as mole cm<sup>-2</sup> h<sup>-1</sup>. These rates are summarized in Fig. 3-5, and presented in detail by Pedersen *et al* (1991). Generally the rates were higher when there were more bacteria present. The bacteria did assimilate CO<sub>2</sub> and lactate and also respired lactate into CO<sub>2</sub>.

Table 3-8 compares rates of assimilation and respiration by an average attached bacteria at a density of 1.8x10<sup>6</sup> cm<sup>-2</sup> in the different populations. The rates were higher in the population from 970-1240 m than from 812-820 m. Raised temperature gave higher assimilation rates.

### 3.8 CO<sub>2</sub> ASSIMILATION/TOTAL CELL CARBON RATIOS

The "autotrophic" evaluation gave results shown in Table 3-9. For example, in the 812-820 m population, the doubling time was 34 days (assuming that growth from day 27-161 was linear). This gives that one bacteria demanded 1.42x10<sup>-17</sup> mole C per hour to be built up. The CO<sub>2</sub> assimilation rate was 1.2x10<sup>-18</sup> mole C per bacterium and day at a density of 1.8x10<sup>6</sup> bacteria per cm<sup>2</sup>. The "autotrophy" quotient was 0.09 (Table 5). For the 970-1240 m population (10°C) the corresponding "autotrophy" quotient was 0.07 and for 20°C it was 0.25 (days 27-71). All quotients are well below 1, indicating that autotrophy is far from enough to support these populations with carbon for growth.

### 3.9 SULPHATE ASSIMILATION AND REDUCTION

Only a few of the slides showed a sulphate assimilation that were more than 50% higher than in the controls. There was no detectable production of sulphide in any of the tubes.

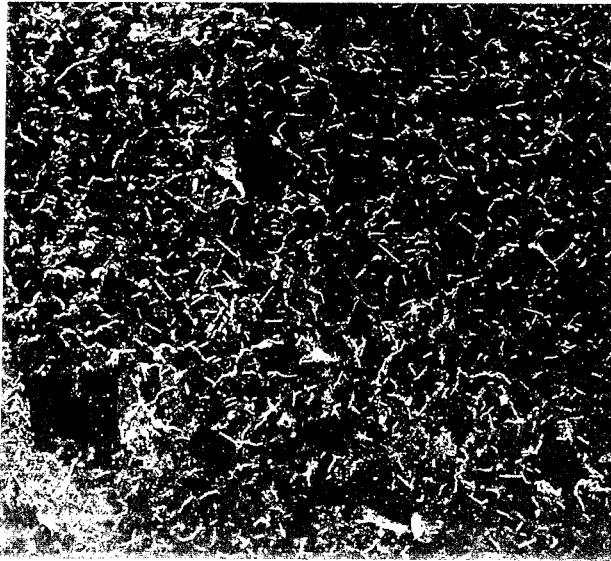

a 20 μm

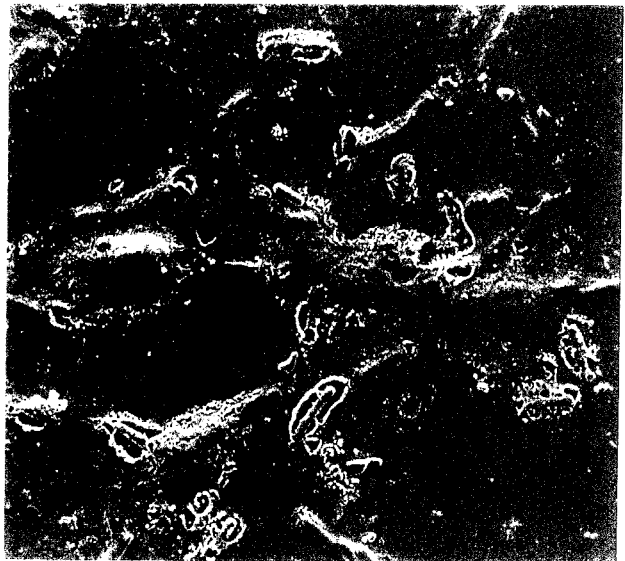

b 2 μm



c 5 μm

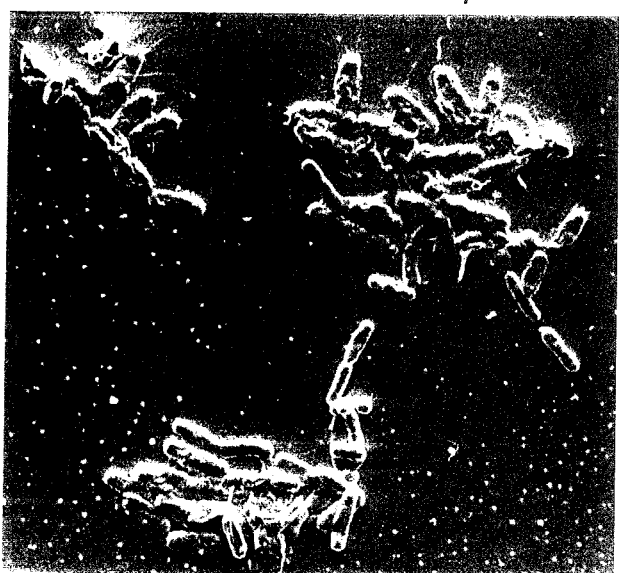

d 2 μm

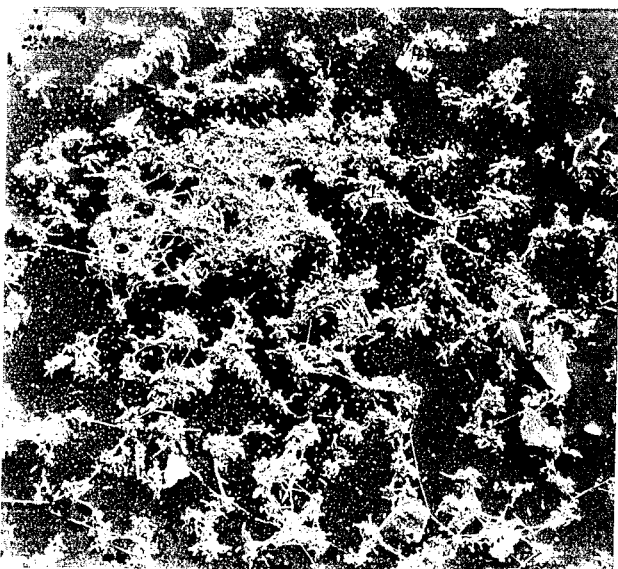

e 20 μm

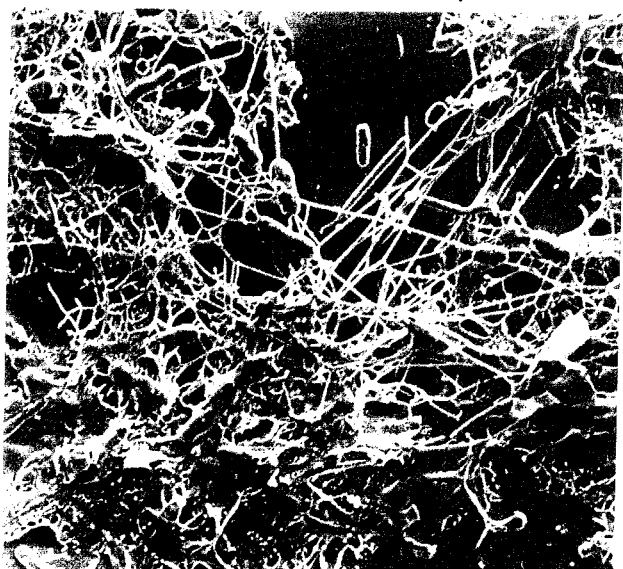

f 2 μm

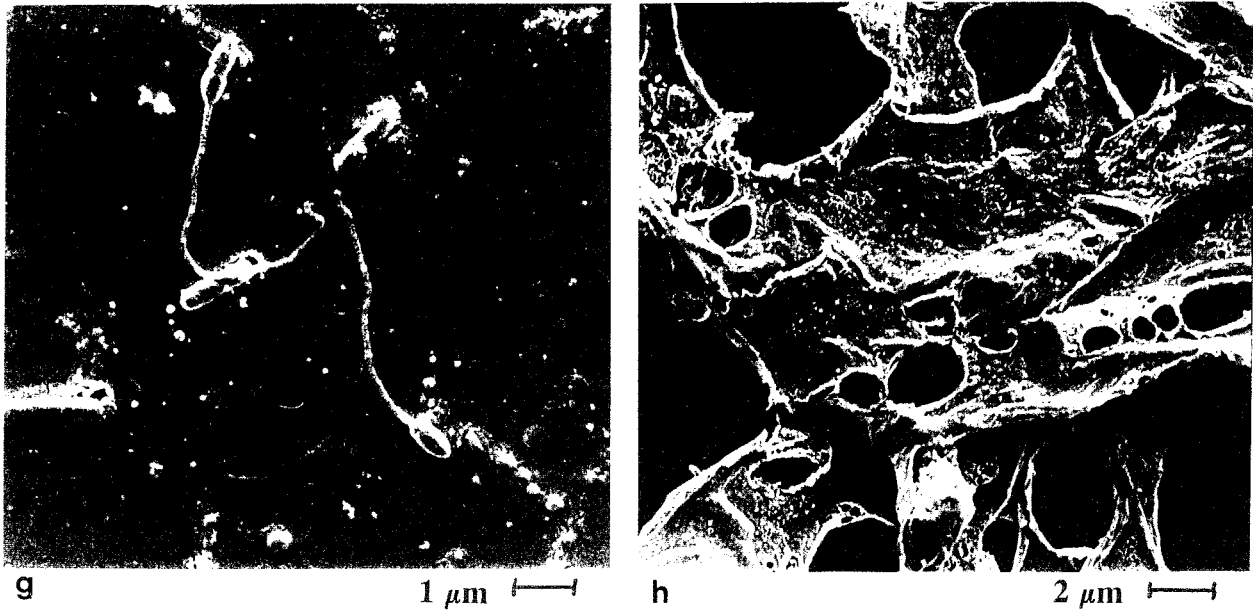

Figure 3-1. SEM images of attached bacteria on microscope slides exposed to flowing groundwater from the Stripa borehole V2. 1a-b: 812-820 m, 10°C, 161 days; 1c-d: 970-1240 m, 10°C, 71 days; 1e-f: 970-1240 m, 20°C 71 days, 1g-h: 812-820 m, 10°C.

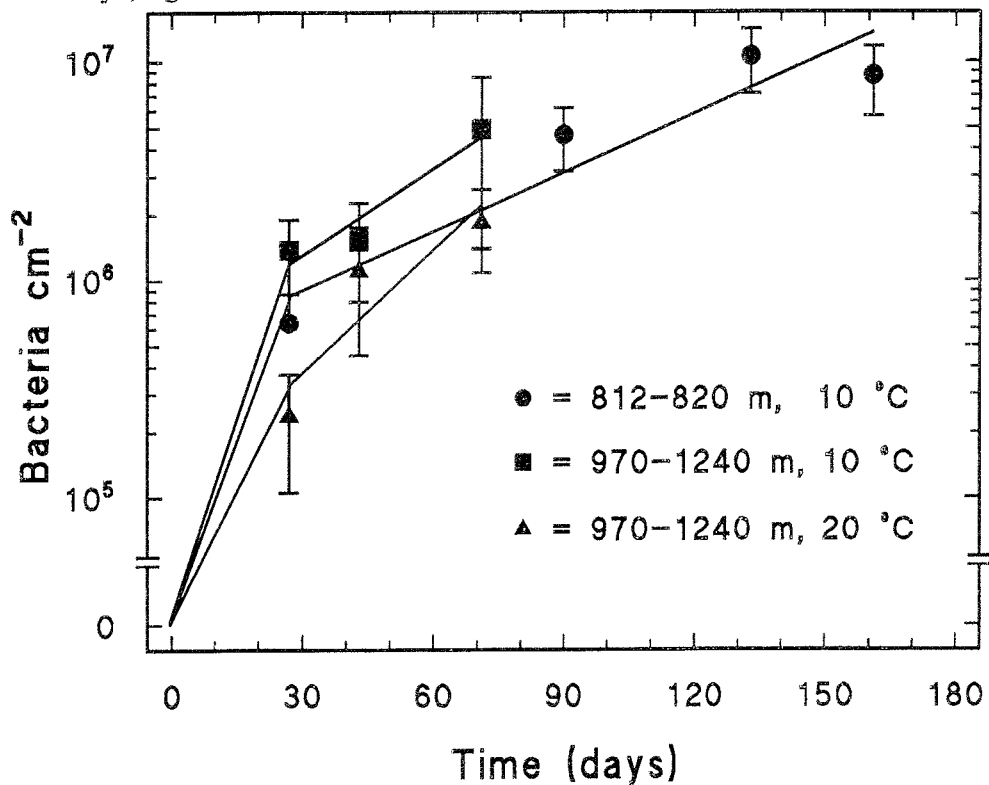

Figure 3-2. The total number of attached bacteria on surfaces exposed to flowing groundwater from the Stripa borehole V2 for different times.

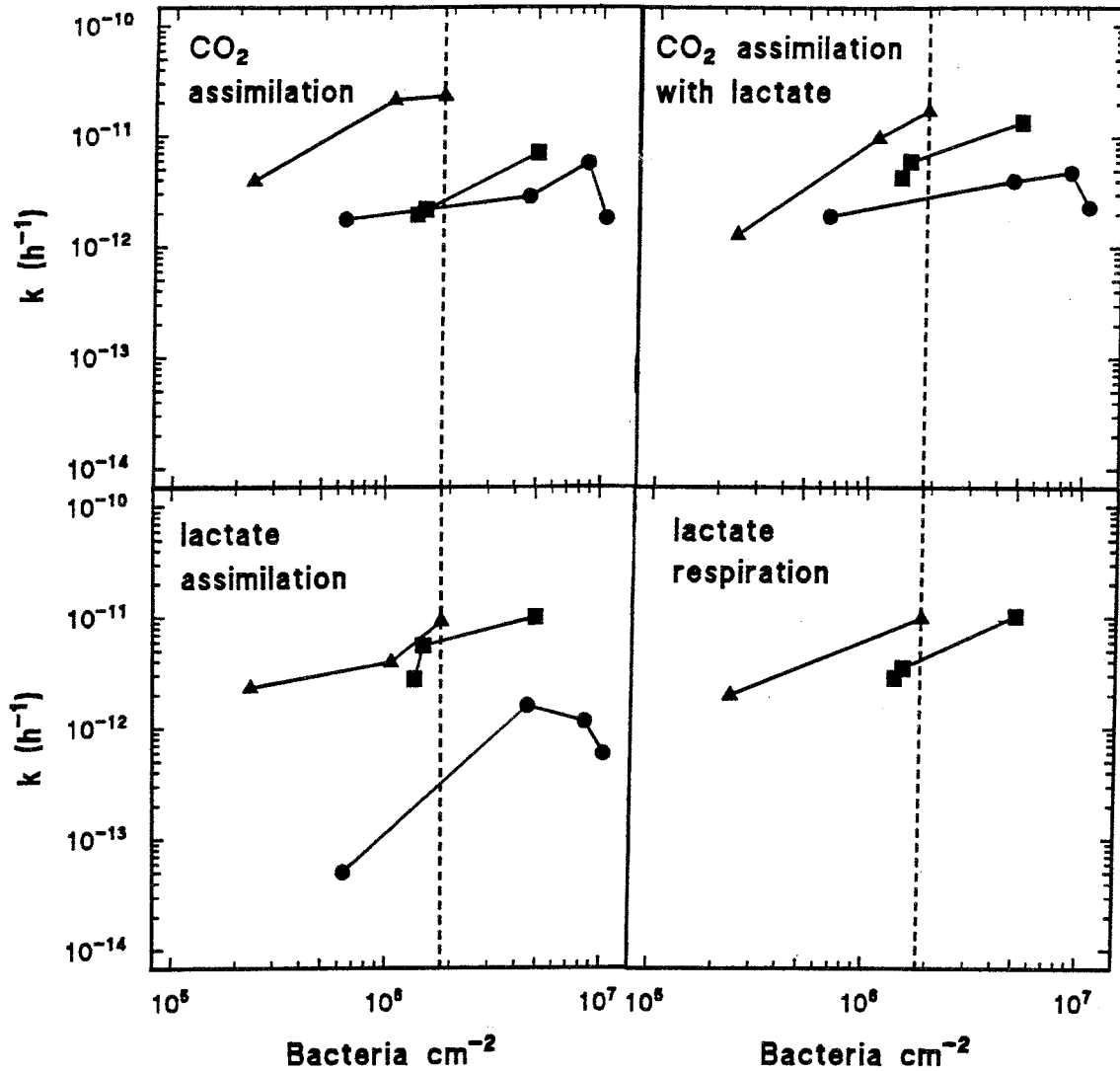

Figure 3-3 The *in situ* assimilation rates of CO<sub>2</sub> without and with the addition of 10 μM unlabelled lactate, the assimilation rates of <sup>14</sup>C from U-[<sup>14</sup>C]-labelled lactate and the respiration rates of assimilated [<sup>14</sup>C]-lactate, measured as <sup>14</sup>CO<sub>2</sub> evolution, by attached bacteria in groundwater from the Stripa borehole V2. Symbols: circle, 812-820 m; square, 970-1240 m, 10°C; triangle, 970-1240 m, 20°C. The dotted line represents 1.8 × 10<sup>6</sup> bacteria cm<sup>-2</sup> and is used for calculations of CO<sub>2</sub> assimilation rates in table 3-8.

Table 3-1 The major parameters of the Stripa borehole V2.

sampling depth (m)	pH	E <sub>h</sub> (mV)	temp <sup>a</sup> (°C)	SO <sub>4</sub> <sup>2-</sup> (μM)	S <sup>2-</sup> (μM)	Fe (μM)	TIC (μM)	conductivity (μS cm <sup>-1</sup> )	flow rate (m sec <sup>-1</sup> )
812- 820	9.4	+199	18	1433	106	0.14	50	1640	2.8 x 10 <sup>-3</sup>
970-1240	10.2	-3	26	520	233	0.07	57	1180	0.5 x 10 <sup>-3</sup>

<sup>a</sup>at sampling depth in the borehole

Table 3-2 The major content of dissolved gases in the the Stripa borehole V2 groundwaters.

sampling depth (m)	H <sub>2</sub> ( $\mu$ M)	He ( $\mu$ M)	N <sub>2</sub> ( $\mu$ M)	O <sub>2</sub> ( $\mu$ M)	CO ( $\mu$ M)	CO <sub>2</sub> ( $\mu$ M)	CH <sub>4</sub> ( $\mu$ M)	C <sub>2</sub> H <sub>6</sub> ( $\mu$ M)	C <sub>2</sub> H <sub>2-4</sub> <sup>a</sup> ( $\mu$ M)	extracted gas (%)
812- 820	<0.4	33	1330	3.4 <sup>b</sup>	<0.04	0.5	7.3	0.03	<0.004	3.4
970-1240	<0.4	16	1055	0 <sup>b</sup>	<0.04	0.4	12.5	0.1	<0.004	2.7

<sup>a</sup> the content of C<sub>2</sub>H<sub>2</sub> + C<sub>2</sub>H<sub>4</sub>

<sup>b</sup> determined with the Winkler titration method



Table 3-3 Total numbers of unattached bacteria of the Stripa borehole V2.

sampling date		N <sup>a</sup>	812-820 m bacteria		970-1240 m bacteria	
			x 10 <sup>5</sup> ml <sup>-1</sup>	SD %	x 10 <sup>5</sup> ml <sup>-1</sup>	SD %
Groundwater sampling						
15 April	1991	3	0.13	59	3.4	21
29 May	1991	2	0.23	14	2.5	11
25 June	1991	2	0.22	49	1.4	79

<sup>a</sup> N is the number of independent samples

Table 3-4

Groundwater bacteria were mixed in two different proportions, DNA extracted, PCR treated, cloned and sequenced. The table shows the species distribution of 12 randomly chosen clones for two different bacterial mixtures and concentrations.

Bacteria in mixture	cell volume ratio	mixture parts	species distribution of clones	
			5x10 <sup>4</sup> cells ml <sup>-1</sup>	1x10 <sup>6</sup> cells ml <sup>-1</sup>
Mixture 1 <i>Desulfomicrobium baculatum</i> : <i>Gallionella ferruginea</i>	1:1	4:1	10:2	10:2
Mixture 2 <i>Bacillus megaterium</i> : <i>Desulfomicrobium baculatum</i> : <i>Gallionella ferruginea</i>	24:1:1	1:1:1	11:1:0	11:1:0

Table 3-5

Groups of bacterial clones screened from two levels of the Stripa borehole V2 and their distribution. DNA from bacteria attached to glass surfaces have been extracted, the 16S-rRNA genes amplified with PCR, cloned and sequenced using primer 907-926. Each of the groups I, II and III contains identical clones. Single observations were not identical.

Clone group	812-820 m, 10°C		970-1240 m, 10°C		970-1240 m, 20°C	
	Number of clones	% of total	Number of clones	% of total	Number of clones	% of total
I	15 (6+9) <sup>a</sup>	63	0 (0+0)	0	0 (0+0)	0
II	2 (2+0)	8	20 (10+10)	83	13 (5+8)	54
III	4 (2+2)	17	1 (1+0)	4	4 (2+2)	17
Single observations	3 (2+1)	12	3 (1+2)	12	7 (5 <sup>b</sup> +2)	29

<sup>a</sup> The number of clones in this clone group achieved in extraction 1 and 2 respectively.

<sup>b</sup> Four of these clones are probably due to contamination, see text for details.

Table 3-6 Comparison of similarity between the sequenced Stripa clone groups and 16S-rRNA sequences in the EMBL database.

Clone group	EMBL Accession number	Overlap, number of basepairs compared <sup>a</sup>	Systematic group <sup>b</sup>	Most related bacteria	% similarity
I	L20810	764	beta Proteobacteria	<i>Pseudomonas solanacearum</i>	91.7
		773		<i>Zoogloea ramigera</i>	91.2
II	L20811	877	beta-1 Proteobacteria	<i>Pseudomonas testosteroni</i>	95.9
		877		<i>Brachymonas denitrificans</i>	94.9
III	L20812	739	gamma Proteobacteria	<i>Acinetobacter calcoaceticus</i>	96.1
		737		<i>Pseudomonas aeruginosa</i>	87.7

<sup>a</sup> between the clone and the most related bacterium

<sup>b</sup> according to signature bases in Woese (1987).



Table 3-8

The *in situ* assimilation rates of CO<sub>2</sub> without and with the addition of 10 μM unlabelled lactate, the assimilation rates of <sup>14</sup>C from U-[<sup>14</sup>C]-labelled lactate and the respiration rates of assimilated [<sup>14</sup>C]-lactate, measured as <sup>14</sup>CO<sub>2</sub> evolution, by an average attached bacterium at a density of 1.8x10<sup>6</sup> bacteria cm<sup>-2</sup>.

Depth m	Temp. °C	CO <sub>2</sub> assimilation  x 10 <sup>-18</sup> mole h <sup>-1</sup> bacterium <sup>-1</sup>	CO <sub>2</sub> assimilation with 10 μM lactate  x 10 <sup>-18</sup> mole h <sup>-1</sup> bacterium <sup>-1</sup>	lactate assimilation  x 10 <sup>-18</sup> mole h <sup>-1</sup> bacterium <sup>-1</sup>	lactate respiration  x 10 <sup>-18</sup> mole h <sup>-1</sup> bacterium <sup>-1</sup>
812- 820	10	1.2	1.6	0.2	n.d. <sup>a</sup>
970-1240	10	1.6	3.6	6.0	2.2
970-1240	20	12.9	9.5	9.1	5.4

<sup>a</sup> not determined

Table 3-9 Data for and calculation of the autotrophic capability of the *Stripa* populations. For a detailed description, see text.

Level	Temp.	Doubling time	Cell volume	Carbon assimilated <sup>a</sup>	Carbon required for growth	"Auto-trophy"
m	°C	days	(V) μm <sup>3</sup>	(A) x 10 <sup>-18</sup> mole C h <sup>-1</sup> bacterium <sup>-1</sup>	(B) x 10 <sup>-18</sup> mole C h <sup>-1</sup> bacterium <sup>-1</sup>	(Q) = (A/B)
812- 820	10	34	0.92	1.2	14.2	0.09
970-1240	10	23	1.01	1.6	23.1	0.07
970-1240	20	16	1.59	12.9	51.9	0.25

<sup>a</sup>from Table 3-8.

## 4 DISCUSSION

The laminar flow reactor has earlier been shown to constitute a reproducible environment for the study of attachment and growth of bacteria (Pedersen 1982). The experimental variance is very low making the reactors well suited for comparisons between environments as were done here. Except for pressure and temperature, the reactor environments were believed to parallel the *in situ* chemical and physical environments reasonable well to make such a comparison valid. One of the most important factors governing attachment and growth of bacteria is the bacterial species itself (Pedersen et al 1986). Depending on species and strain, different attachment patterns are obtained. The opposite process, separation from the surface, occurs during multiplication of irreversibly attached bacteria and as desorption of reversibly attached bacteria in laminar flow systems (Escher and Caracklis 1990). Here, the reactors were used as a first approximation of a fracture surface with the assumption that some of the dominating bacteria growing on fracture surfaces in the deep environment will detach, move with the flowing water, attach and grow again, eventually in the reactor environment imitating the *in situ* situation.

### 4.1 HETEROGENEITY BETWEEN SAMPLING LEVELS

The chemical data, the bacterial numbers counted in the Stripa groundwater and the different populations growing on the slides reflect a heterogeneity between the sampled levels. This heterogeneity was also observed when the salinity profile was studied (Nordstrom et al 1985). It shows that the groundwaters came from fracture systems without close interconnections. The content of sulphide and trace amounts of oxygen in the groundwater from the 812-820 m level indicates that this water might have been a mix of oxic and anoxic waters from different fractures. The results from using 16S-rRNA gene sequencing of the attached Stripa populations (Table 3-5) revealed that there were different populations at each of the two levels studied in this borehole. Three dominating groups of Proteobacteria were found. One of them was found only at 812-820 m,



where 63 % of the bacteria belonged to this group. A second existed almost exclusively and also dominating (83% at 10°C, 65% at 20°C) at 970-1240 m, and a third was equally distributed between the levels (17% at 812-820 m, 4% and 17% at 970-1240 m, 10 and 20°C, respectively). The assimilation rates of both CO<sub>2</sub> and lactate were faster at the deeper (970-1240 m) compared to the upper level (812-820 m). The increased rates of the 970-1240 m population at 20°C compared to 10°C were most likely an effect of temperature. Bacteria usually increases their enzyme activities when temperature is raised. The population morphology also differed according to SEM images (Figure 3-1), but the population structure was not altered to any great extent by the shift in temperature as shown by our 16S-rRNA studies (Table 3-5). The sampled ecosystems thus contained very few species of bacteria showing different metabolic activities and it seems clear that the spatial distribution of bacteria in the studied rock was dependent on the surrounding environment.

The origin of the observed bacteria is difficult to determine. Stevens *et al.* (1993) report a study on deep groundwater bacteria in drilled artesian wells in Washington, USA, and argued that the anaerobic, alkaline groundwaters favour the growth of aquifer organisms over growth of most contaminants being introduced from the surface. Likewise it can be speculated that the found bacteria were true inhabitants of the Stripa borehole V2. For a more detailed discussion about the origin of these bacterial populations, see Pedersen & Ekendahl (1992a).

## 4.2 SEM STUDIES

Our SEM images of the glass surfaces indicated that the two levels in the borehole had populations that were different. The bacteria were mostly rods, but differed slightly in size between the levels (Fig. 3-1). Within the deeper level, the bacteria at 20°C had a different morphology compared to at 10°C, possibly due to physiological changes at the higher temperature. They seem to have excreted thin threads that might act as holdfasts or for cell-cell interactions. The threads might also be extra-cellular material that covered the whole colonies but dried during SEM dehydration (Fig. 3-1h), but this seems less probable if judged from the images.

## 4.3 ENRICHMENTS

All attempts to enrich and grow the viable Stripa bacteria failed. Earlier attempts to culture them on plate count growth media for heterotrophs with and without oxygen resulted in less than 1% of the total population growing (Pedersen 1988). The negative plate count and enrichment results strengthen the importance of methods in microbial ecology that are

independent of culturing techniques, as the molecular method described and used here.

#### 4.4 DNA TECHNIQUES

Knowledge of the bacterial species present in an ecological system is of interest to evaluate the specific properties and functions of the system. Good methods for enumeration and identification of these species or groups are necessary. In this study we have used a molecular method that can reveal both cultivable as well as uncultivable bacteria in deep groundwater. We have regarded our results as an approximate true reflection of the actual distribution of different bacterial cells in the original samples, based on the following discussion.

##### 4.4.1 DNA extraction

Grampositive bacteria and archaeobacteria are generally more resistant to cell lysis than gramnegatives (Stackenbrandt and Goodfellow 1991) because of stronger and different cell walls. Since the bacteria in our samples were uncultivable, it was not possible to use for instance antibiotics to weaken the cells before lysis (Ward et al 1992). We used both SDS, lysozyme and proteinase in the lysis step, and there was no problem to extract the dominating bacteria. Control experiments showed that the lysis of cells in a sample was complete or near complete.

##### 4.4.2 Amplifying genes with PCR

The PCR method is fast, technically simple, and - important in our case - sensitive to small amounts of DNA. It has become a major tool in studies of genomic relatedness. One drawback is the sensitivity to contamination. The PCR conditions must be very strictly controlled and have a negative control. Our controls were negative. The PCR method may not amplify all rRNA gene sequences to the same extent. Small differences in rRNA gene sequences from pure cultures and also in universally conserved regions of some small rRNAs have been reported (Ward et al 1992). Differential or imperfect annealing of primers due to these differences in universal regions or to inappropriate hybridization stringency may cause errors which are amplified in the PCR reaction. An archaeobacterium having an intron within its' 16S rRNA gene have been found (Ward et al 1992). If such bacteria were present in our samples and had the intron where the primer should anneal, it would not be amplified. Likewise, microheterogeneity within 5S rDNA have been found (Davies and Nomura 1972). These small differences are not thought to have any significance in ribosome function.

We used the PCR for amplifying rRNA genes from mixed natural populations instead of rRNA itself, thereby avoiding the sometimes great variation in transcription activity between bacteria at different growth conditions. There may be up to 71 000 rRNA copies in actively growing cells (Ward et al 1992). The number of 16S-rRNA genes also vary somewhat among different species. Archaeobacteria usually have single copies of the rRNA gene, while eubacteria commonly have 5-10 copies per haploid genome (Davies and Nomura 1972; Olsen et al 1986; Ward et al 1992). For example, *Escherichia coli* have 7 rRNA operons in its genome, each containing one 16S-rRNA gene. The control experiment for quantitative PCR (Table 2) indicated that the used PCR technique was quantitative for populations with equal sized bacteria in addition to its qualitative nature, but biased when bacteria of different sizes were investigated. This result indicates that bacteria may have rRNA gene copies in relation to their size, which seems reasonable. The transcription activity per rRNA gene locus at defined growth conditions will then be approximately constant and independent of large differences in size for bacteria with similar growth kinetics and comparable growth rates.

The organization of these multi-copy genes is remarkably stable, but recombinations and mutations have been reported to occur between these operons (Ingraham et al 1987). Although differences in the *Escherichia coli* operons exist, they are virtually (>99%) identical. The possibility thus exists that a single cell could have different 16S-rRNA genes. An example is *Haloarctula marismortui* which express different rRNA sequences simultaneously (Ward et al 1992). Although too few species seem to have been investigated for gene copy differences, it seems unlikely that great differences should be common, since rRNA genes are so important for the cell. Transfer of rRNA genes between species has not been reported.

To get the gene abundance for a particular species, one should multiply the number of cells of the studied species with the number of rRNA gene copies per cell (Ward et al 1992). The specific/total rRNA gene ratios achieved in this study is thus an approximate and not an absolute estimate of cell numbers, but are more accurate for estimating organism abundance than the rRNA ratios. In our study we did not detect any archaeobacteria and the size distribution of the investigated bacteria were equal in the different samples, which indicates the clone distribution results to be an accurate approximation of the relative species abundance.

#### 4.4.3 Cloning

The cloning of PCR fragments is efficient for creating clone libraries and - as in this study - for separating the different 16S-rRNA genes in mixed natural populations. The cloning step is a random process (Prescott et al 1993), since each piece of foreign DNA is inserted into any of the available plasmids, and any of the plasmids is transformed into any of the competent *Escherichia coli* cells. This process does not affect the final

result in clone distribution more than statistically. Considering the 5-10 16S-rRNA genes present in each eubacterium as opposed to the number of cells and the enormous amount of DNA created in the PCR reaction, there is only a small probability that the clones selected for further studies have inserts from the same cell. It is therefore reasonably certain that sequence differences reflect the input of different microorganisms (Ward et al 1992). We selected all clones randomly and chose to study 12 clones from each DNA-extraction. This allowed us to detect the most frequently occurring bacteria in the population, and we considered this to be enough for the purpose of the study. However, we found bacteria resembling *Planctomyces* in the AODC and *Caulobacter* at the SEM images (Fig. 3-1g) which were too few to appear among the clones sequenced.

#### 4.4.4 Sequencing

The method of sequencing genes, the 16S-rRNA gene in particular, has become a major breakthrough in evolutionary and phylogenetic studies of procaryotes and is now becoming a standard technique. The 16S-rRNA molecule is universally distributed in nature, functionally homologous and has highly conserved regions suitable for such studies. Sequencing small but informative domains of the gene - as we did with our clones - gives a relatively quick answer to who the bacteria in mixed populations are, or at least to where in the systematics they belong.

#### 4.4.5 Sequence analysis

We used both the EMBL database and signature bases in unrestricted and restricted analysis to reveal the bacteria most related to our clones. The similarity values become only slightly higher when we compare unambiguously alignable positions of the 16S-rDNA using an eubacterial mask according to Lane (Lane 1991). We have consciously refrained from creating a phylogenetic tree since there is, as yet, no established analysis method.

The clones in each of the three major groups in this study do not necessarily belong to the same species or strain, since they may differ in one or a few bases in the variable 16S-rDNA regions not sequenced here. A similarity difference of 1-2% might on the other hand be attributed to cloning or sequencing artifacts. The clones in each group should anyhow be very closely related.

### 4.5 PHYLOGENY

All of the found bacteria belong to the Proteobacteria. Two of the major groups fall into the beta group of Proteobacteria and the third into the gamma group of the Proteobacteria. None of the sequences from the three

groups was identical to any of the bacteria in the database. Either these bacteria have been earlier characterized but not yet sequenced, or they are until now undiscovered species. The obtained similarity values between the clone groups and the bacteria in the database are far too remote to make comparisons of their phenotypic characters reasonable (Table 3-6). There is at present only a limited amount of 16S-rRNA gene sequences available in the databases. New bacterial sequences appear continually and the databases often have to be updated. In the future, bacteria with higher similarity values to our clones is likely to be found.

Several of the single observations showed close relation to the dominating groups and differed by only a few bases. Thus the dominating groups may have even greater importance in their ecological impact. Different electron acceptors and what activities these bacteria had are discussed below.

#### 4.6 COMPARISON BETWEEN THE DIFFERENT POPULATIONS

It can be seen from the distribution of clones (Table 3-5) that there was a difference between the populations at the two depths of the investigated borehole. The beta Proteobacteria in group I was found only at the higher level in the borehole, whereas the beta Proteobacteria in group II, was found almost exclusively at the deeper level. Two clones from group II were however found at the higher level. As shown, the conditions at the levels differ in for example pH, temperature, redox, flow rate, content of sulphate, iron, and sulphide (table 3-1 and 3-2). The numbers of bacteria in the bulk water phase, the CO<sub>2</sub> assimilation and lactate respiration rates on glass slides were higher at the deeper level (table 3-3). The bacterial groups present may then be selectively adapted to these different environments. For example, it can be speculated that since there was a high redox value and traces of oxygen at 812-820 m, the group I bacteria dominating this level may be more adapted to a facultative anaerobic metabolism while the group II bacteria perhaps are obligate anaerobes that instead will thrive in the anoxic, sulphide rich, low redox ground water at 970-1240 m. It becomes clear that the environment sets the limits for which bacteria can be present and that the obtained results probably reflect "the dominance of the fittest". One dominating species in the laminar flow reactors at each level then indicate that the environment might have been difficult to adapt to because of more or less extreme conditions. The situation in the rock is probably similar with only a few dominating bacteria present.

The gamma Proteobacteria in group III was equally distributed between the levels. The different temperatures at the deeper level had very little effect on species composition, though there is a slight indication that group II bacteria thrive better in 10 than in 20°C.

#### 4.7 STUDYING DEEP GROUNDWATER BACTERIA

By extracting, cloning and sequencing the 16S-rRNA genes from mixed populations of bacteria from two different depths of deep granitic groundwater in fractured rock, we have been able to measure the distribution and frequencies of three different dominating bacterial groups in this environment. The molecular protocol was repeated on separate DNA extractions as a control for the variance in the used methods. The results support the high fidelity of rRNA gene cloning and sequencing methods.

To make the description of bacterial populations complete and to reliably identify and characterize environmental samples, both the genotypic and phenotypic characterization must be used in polyphasic taxonomy. By combining studies on physiology, morphology and the molecular composition of deep groundwater populations, with methods like labelling and scintillation counts, SEM and sequencing, we have found some of the answers to our questions about deep granitic groundwater microbial ecosystems. The study presented here establish our theory that there is a pronounced spatial distribution of bacteria between sampling sites as a function of environmental conditions. We have now continued our investigations on bacterial populations in deep granitic bed-rock at the Äspö Hard Rock Laboratory (Gustafsson *et al.*, 1988, 1989, 1991), which is under construction on the southeast coast of Sweden. Preliminary results confirm a pronounced spatial distribution of subterranean bacteria, also reported from other sites (Pedersen, 1993a). With the use of the techniques discussed above and also other techniques, like fluorescent molecular probes and anaerobic viable counts to quantify bacterial species *in situ*, we continue to investigate the structure of deep ground water populations, what governs their existence and activity, and also what effect they may have on the surrounding environment.

#### 4.8 ELECTRON ACCEPTORS AND BACTERIAL GROUPS

Electron acceptors like oxygen, nitrate and nitrite were not available in amounts to be likely to dominate the metabolism of the Stripa bacteria. Methanogenic bacteria have earlier been proposed to exist in the Stripa groundwater (Pedersen & Ekendahl, 1992a). They can use carbon dioxide as both carbon source and terminal electron acceptor to produce methane. Both carbon dioxide and methane were present in the waters (Table 3-2). However, since no Archaeobacteria was found in the 16S-rRNA gene sequencing study, they should not be abundant, at least in the reactor environment.

It has earlier been proposed that since the Stripa bacteria readily assimilated lactate anaerobically (Pedersen and Ekendahl 1992a) the

dominating species might be sulphate reducing bacteria (SRB). Fritz *et al.* (1989) used carbon isotope fractionation to draw the conclusion that SRB were present in the Stripa groundwaters. In addition, Fontes *et al.* (1989) got isotope data that proved bacterial enhanced redox processes to play an important role in the control of the concentration and heavy isotope contents of aqueous sulphate in Stripa. But sulphate reduction could not be demonstrated even though sulphate is the most abundant electron acceptor available. The molecular identification with 16S-rRNA gene sequencing techniques to reveal the nature of the biofilm populations showed that the dominating bacteria belonged to the beta and gamma groups of the Proteobacteria, and not to the delta group where all known SRB belong. Therefore the conclusion was made that no or very few SRB were present. This result does not necessarily contradict the stable isotope data. Dating with  $^{14}\text{C}$  analysis indicates groundwater ages of 5000 - 20,000 years (Nordstrom *et al.*, 1985), so the stable isotope profile may have been formed back in time. It is also possible that the sulphate reducing activity occurred in other geological formations than that intersected by the borehole V2, perhaps during infiltration of surface waters rich in organic carbon.

There are findings showing that in addition to sorbing metals (Beveridge and Fyfe 1985; Pedersen and Albinsson 1991; Shuttleworth and Unz 1993; Strandberg *et al.* 1981), bacteria can couple anaerobic metal reduction to organic carbon oxidation or growth (Arnold *et al.* 1986; Lovley 1991; Nelson and Myers 1992). Metals often discussed are manganese-(IV) (Lovley *et al.* 1989), uranium-(VI) (Lovley *et al.* 1991) and iron-(III) (Lovley and Phillips 1988, Lovley *et al.* 1987, 1992). Manganese were below detection limits and uranium exist in the form of U-(IV) at the prevailing pH in the Stripa waters. However, iron was present in the groundwater. The total iron concentrations measured earlier in 19 samples from Stripa groundwaters (Nordstrom *et al.* 1985) were usually below 1  $\mu\text{M}$  as in the studied borehole (Table 3-1). It has been reported that SRB (and also methanogens) are competitively excluded and less active in high-iron groundwater where iron-reducers are present (Chapelle and Lovley 1992; Lovley and Phillips 1987). Iron reduction may be thermodynamically favourable, since the redox potential for Fe(III) lies near nitrate and well above sulphate (Nelson and Myers 1992). The iron reducers keep the levels of the dissolved electron donors hydrogen, formate and acetate too low for the sulphate reducers to metabolize. This occurs when the Fe(III) is in a form that Fe(III)-reducing organisms can readily utilize, which is usually in the form of amorphous Fe(III) oxyhydroxides. When the levels of Fe(III) oxyhydroxides are scarce or electron donors in excess, sulphate reduction takes over or is at least not inhibited.

#### 4.9 AUTOTROPHY OR HETEROTROPHY?

Comparing the amount of carbon dioxide assimilated during a certain time and the amount of carbon needed to build up a bacterium growing during that time, the capability for "autotrophy" can be evaluated. The quotients calculated for carbon utilization were between 0.07 and 0.25 (Table 3-9), indicating that autotrophy could not support the levels of growth observed and that heterotrophy was the dominating carbon transformation process for growth of the studied populations. The CO<sub>2</sub> assimilation did not decrease consistently (Table 3-8) when lactate was added, suggesting that there were no autotrophs changing to a heterotrophic metabolism (Hallbeck and Pedersen, 1991) when organic carbon appeared. The measured CO<sub>2</sub> assimilation may thus have been due to heterotrophs using CO<sub>2</sub> for anaplerotic reactions to replace intermediates in *i.e.* the tricarboxylic acid cycle. It is important to use several different carbon sources for assimilation experiments, as shown in previous Stripa V2 studies (Pedersen and Ekendahl 1992a). One reason is that different carbon sources are utilized at varying degrees by the same species. The earlier observed utilizations of added lactate and also glucose, leucine and some formate by parts of the populations support that heterotrophs were present. The Stripa bacteria could further be seen not only to assimilate but also to catabolize lactate and release CO<sub>2</sub> from lactate (Table 3-8), which adds to the indications of a heterotrophic dominance in the Stripa environment.

#### 4.10 CARBON TRANSFORMATIONS IN THE STUDIED GROUNDWATERS

With the laminar flow reactor as a model system, the amount of inorganic carbon (TIC) flowing through a reactor can be compared with the assimilation of CO<sub>2</sub> by the attached bacteria. The flow rates were 66.3 ml min<sup>-1</sup> (812-820 m) and 12.4 ml min<sup>-1</sup> (970-1240 m). Multiplying the TIC values from Table 3-1 with the amount of water flowing through the reactor during one hour, the TIC flow rates were 200 μmole h<sup>-1</sup> (812-820 m) and 42 μmole h<sup>-1</sup> (970-1240 m). Using 1.8x10<sup>6</sup> bacteria per cm<sup>2</sup> as a common value for bacterial density (Table 3-8), there were 1.45x10<sup>9</sup> bacteria per reactor growing on a surface area of 806.4 cm<sup>2</sup>. The CO<sub>2</sub> assimilation data from Table 3-8 was then multiplied with the numbers of bacteria in the reactor to give the total assimilation during one hour. These values of total assimilation in the reactor were divided with the TIC flow rate values, and the results show that the bacteria assimilated between 1/100 000 and 44/100 000 of the TIC passing through with the water.

Moving from our reactor model system to a typical hard rock fracture, the water flow rate and the volume/surface area ratio will decrease. Since channelling of the groundwater has been suggested to dominate in bed-rock we assumed a fracture width of 0.1 mm with sides of 1 cm<sup>2</sup> (Moreno et al 1988) and used TIC values from Table 1 and bacterial density and assimilation data from Table 3-8 in the following calculations. At the 812-



820 m level, the flow rate was  $2.8 \text{ mm s}^{-1}$  (Table 3-1) and it would take 3.57 s for 0.01 ml of water to pass a channel area of  $2.02 \text{ cm}^2$ . During that time  $4.3 \times 10^{-15}$  mole  $\text{CO}_2$  would be assimilated by the attached bacteria. The quotient between this calculated figure and the measured TIC (0.5 nmole in 0.01 ml of water, from Table 3-1) is  $8.7 \times 10^{-6}$ . Thus, during 3.57 s, one part out of approximately 115 000 ( $1/8.7 \times 10^{-6}$ ) of the TIC in the water would be utilized for each cm of bed-rock channel through which the groundwater flows. Considering a "plug flow" (the water moves without mixing with new water), the TIC would be depleted after a flow distance of 1.15 km or after 115 hours, provided no addition of carbonate from degradation of organic matter or dissolution of mineral occurred. The values for the 970-1240 m level, (flow rate  $0.5 \text{ mm s}^{-1}$ ),  $10^\circ\text{C}$  and  $20^\circ\text{C}$  were 176 m and 98 h and 22 m and 12 h respectively. It becomes obvious that the measured  $\text{CO}_2$  assimilation must have been balanced by a respiratory activity, indicated by the autotrophy quotients (Table 3-9) to be 4 to 14 times larger than the  $\text{CO}_2$  assimilation activity.

Indeed, the biofilm bacteria studied respired added lactate and the  $\text{CO}_2$  released represented 7/100 000 to 18/100 000 of the TIC flowing through the reactors, but this figure is lower than the  $\text{CO}_2$  assimilation calculated above. The biofilm bacteria obviously must have metabolized organic carbon compounds present in the groundwater other than lactate if a steady state between assimilated and produced  $\text{CO}_2$  is anticipated.

There were typically between 30 and  $300 \mu\text{mole l}^{-1}$  of dissolved organic carbon (DOC) in the groundwaters studied (Pettersson et al 1990) and methane. About 50 % of this DOC was composed of complex humic and fulvic acids, and a smaller part was organic substances with shorter carbon chains than glucose. The sources of this organic carbon is unexplored. It may be organic material percolating down from the ground surface, but as dating with  $^{14}\text{C}$  analysis indicates groundwater ages of 5000 - 20,000 years (Nordstrom et al 1985), it seems to be a less plausible explanation. The other possible source would be organic deposits in the rock or organic compounds migrating up from very deep layers of the earth (Gold 1992). It will be an important task to investigate the sources and fluxes of organic carbon in the subterranean environment. The results presented here indicate such carbon to be the main fuel for bacterial processes of importance for nuclear waste disposal and the fluxes will then determine the process rates. Investigations of bacterial carbon transformations and the ecology of important groups of deep granitic groundwater bacteria will be continued and are now concentrated to the environment around the Äspö Hard Rock Laboratory (Gustavsson et al 1988, 1989, 1991) now under construction on the Swedish east coast.

## 5 ACKNOWLEDGEMENTS

We thank our mine guide, Birger Ekstrand, and the director of the mine, Gunnar Ramqvist, for pleasant collaboration at the Stripa mine. This research was supported by the Swedish Nuclear Fuel and Waste Management Co.

## 6 REFERENCES

- Amann, R., N. Springer, W. Ludwig, H.-D. Görtz, and K.-H. Schleifer. 1991. Identification in situ and phylogeny of uncultured bacterial endosymbionts. *Nature*. 351:161-164.
- Arnold, R.G., T.J. DiChristina, and M.R. Hoffmann. 1986. Inhibitor studies of dissimilative Fe(III) reduction by *Pseudomonas* sp. strain 200 ("*Pseudomonas ferrireductans*"). *Applied and Environmental Microbiology*. 52:281-289.
- Balkwill, D.L., F.R. Leach, J.T. Wilson, J.F. McNabb, and D.C. White. 1988. Equivalence of microbial biomass measures based on membrane lipid and cell wall components, adenosine triphosphate, and direct counts in subsurface aquifer sediments. *Microbial Ecology*. 16:73-84.
- Beveridge, T.J., and W.S. Fyfe. 1985. Metal fixation by bacterial cell walls. *Canadian Journal of Earth Science*. 22:1893-1898.
- Brosius, J., M. L. Palmer, P. J. Kennedy, and H. F. Noller. 1978. Complete nucleotide sequence of a ribosomal RNA gene from *Escherichia coli*. *Proceedings of the National Academy of Science USA*. 75:4801-4805.
- Carritt, D. E., and J. H. Carpenter. 1972. Dissolved oxygen concentration and saturation, p. 24-29. In S. R. Carlberg (ed.), *Coop. Research Report, series A:29. New Baltic Manual with methods for sampling and analyses of physical, chemical and biological parameters*. Int. Council for the exploration of the sea, Denmark.
- Chapelle, F. H., and D. R. Lovley. 1992. Competitive exclusion of sulfate reduction by Fe(III)-reducing bacteria: A mechanism for producing discrete zones of high-iron groundwater. *Ground Water*. 30:29-36.
- Davies, J., and M. Nomura. 1972. The genetics of bacterial ribosomes., p. 203-234. In H.L. Roman, L.M. Sandler, and A. Campbell (ed.), *Annual review of genetics*. Annual Reviews Inc., Palo Alto, Ca, USA.
- Erlich, H.L. 1990. *Geomicrobiology*. 2nd ed. Marcel Dekker, Inc. New York.

- Escher, A. & Characklis, W.G. (1990) Modeling the initial events in biofilm accumulation. In *Biofilms*, pp 445-486. Edited by W.G. Characklis & K.C. Marshall. Chichester:John Wiley & Sons, Inc.
- Fontes, J.C., P. Fritz, D. Louvat, and J.L. Michelot. 1989. Aqueous esulfates from the Stripa groundwater system. *Geochimica et Cosmochimica Acta*. 53:1783-1790.
- Fossing, H., and B. B. Jørgensen. 1989. Measurement of bacterial sulfate reduction in sediments: evaluation of a single step chromium reduction method. *Biogeochemistry*. 8:205-222.
- Franson, M.A.H. 1985. Standard methods for the examination of water and wastewater. 16th edition. AWWA-APHA-WPCF, Washington D.C., USA.
- Fritz, P., J.-C. Fontes, S. K. Frapé, D. Louvat, J.-L. Michelot, and W. Balderer. 1989. The isotope geochemistry of carbon in groundwater at Stripa. *Geochimica et Cosmochimica Acta* 53:1765-1775.
- Gold, T. 1992. The deep hot biosphere. *Proceedings of the National Academy of Science USA*. 89:6045-6049.
- Ghiorse, W.C., and D.L. Balkwill. 1983. Enumeration and morfological characterization of bacteria indigenous to subsurface environments. *Developments in Industrial Microbiology*. 24:213-224.
- Giovannoni, S.J., T.B. Britschgi, C.L. Moyer, and K.G. Field. 1990. Genetic diversity in Sargasso sea bacterioplankton. *Nature*. 345:60-63.
- Grigorova, R., and J.R. Norris. 1990. Size estimation., p. 56-67. In R. Grigorova, and J.R. Norris (eds.), *Methods in Microbiology*, vol.22, Academic press, London.
- Gustafsson, G., Stanfors, R., and P. Wikberg 1988 Swedish hard rock laboratory first evaluation of preinvestigations 1986-1987 and target area characterization. SKB Technical report, 1988, 88-16, Stockholm. Available from SKB, Box 5864, 102 48 Stockholm, Sweden, tel. +46-8-665 28 00
- Gustafsson, G. Stanfors, R., and P. Wikberg 1989 Swedish hard rock laboratory first evaluation of preinvestigations 1988 and target area characterization. SKB Technical report, 1989, 89-16, Stockholm. Available from SKB, Box 5864, 102 48 Stockholm, Sweden, tel. +46-8-665 28 00
- Gustafsson, G., Liedholm, M., Rhén, I., and R. Stanfors Wikberg P 1991 Äspö hard rock laboratory. Predictions prior to excavation and the process of their validation. SKB technical report, 91-23, Stockholm. Swedish nuclear fuel and waste management co., Box 5864, S-102 48 Stockholm
- Hallbeck, L., and K. Pedersen 1991. Autotrophic and mixotrophic growth of *Gallionella ferruginea*. *Journal of General Microbiology* 137:2657-2661.

- Holt, J.G. 1984-89. Bergey's manual of systematic bacteriology, vol. 1-4. Williams & Wilkins, Baltimore.
- Huffman, E.D.W. 1977. Performance of a new automatic carbon dioxide coulometer. *Microchemical Journal* 22:567-573.
- Ingraham, J. L., K.B. Low, B. Magasanik, M. Schaechter, and H.E. Umbarger (ed.). 1987. *Escherichia coli* and *Salmonella typhimurium*: Cellular and molecular biology., vol. 1-2. American Society for Microbiology, Washington D.C.
- Johnson, J.L. 1991. Isolation and purification of nucleic acids., p. 1-19. In E. Stackebrandt and M. Goodfellow (ed.), *Nucleic acid techniques in bacterial systematics*. John Wiley & Sons, Chichester.
- Lane, D. J. 1991. 16S/23S rRNA sequencing., p. 115-175. In E. Stackebrandt and M. Goodfellow (ed.), *Nucleic acid techniques in bacterial systematics*. John Wiley & Sons, Chichester.
- Lovley, D.R. 1991. Dissimilatory Fe(III) and Mn(IV) reduction. *Microbiological Reviews*, 55:259-287.
- Lovley, D.R., and E.J.P. Phillips. 1987. Competitive mechanisms for inhibition of sulfate reduction and methane production in the zone of ferric iron reduction in sediments. *Applied and Environmental Microbiology*. 53:2636-2641.
- Lovley, D.R., J.F. Stolz, G.L.J. Nord, and E.J.P. Phillips. 1987. Anaerobic production of magnetite by a dissimilatory iron-reducing microorganism. *Nature*. 330:252-254.
- Lovley, D.R., and E.J.P. Phillips. 1988. Novel mode of microbial energy metabolism: Organic carbon oxidation coupled to dissimilatory reduction of iron or manganese. *Applied and Environmental Microbiology*. 54:1472-1480.
- Lovley, D.R., E.J.P. Phillips, and D.J. Lonergan. 1989. Hydrogen and formate oxidation coupled to dissimilatory reduction of iron or manganese by *Alteromonas putrefaciens*. *Applied and Environmental Microbiology*. 55:700-706.
- Lovley, D. R., E. J. P. Phillips, Y. A. Gorby, and E. R. Landa. 1991. Microbial reduction of uranium. *Nature*. 350:413-416.
- Lovley, D.R., E.J.P. Phillips, F.J. Caccavo, K.H. Nealson, and C. Myers. 1992. Letter to the editor: Acetate oxidation by dissimilatory Fe(III) reducers. *Applied and Environmental Microbiology*. 58:3205-3208.
- Ludwig, W. 1991. DNA sequencing in bacterial systematics., p. 69-94. In E. Stackebrandt and M. Goodfellow (ed.), *Nucleic acid techniques in bacterial systematics*. John Wiley & Sons, Chichester.

- Maniatis, T. E., E. F. Fritsch, and J. Sambrook. 1982. *Molecular cloning: a laboratory manual*. Cold Spring Harbor Laboratory, Cold Spring Harbor, N.Y.
- Marmur, J. A. 1961. A procedure for the isolation of deoxyribonucleic acid from microorganisms. *Journal of Molecular Biology* 3:208-218.
- Moreno, L., Y. W. Tsang, C. F. Tsang, F. V. Hale, and I. Neretnieks. 1988. Flow and tracer transport in a single fracture. A stochastic model and its relation to some field observations. *Water Resources Research*. 24:2033-2048.
- Nealson, K.H., and C.R. Myers. 1992. Minireview: Microbial reduction of manganese and iron: New approaches to carbon cycling. *Applied and Environmental Microbiology*. 58:439-443.
- Neidhardt, F. C., J. L. Ingraham, and M. Schaechter. 1990. *Physiology of the Bacterial Cell: A molecular approach*, pp. 1-29. Sinauer Associates, Inc., Sunderland, Massachusetts.
- Nordstrom, D.K., J.N. Andrews, L. Carlsson, J.-C. Fontes, P. Fritz, H. Moser, and T. Olsson. 1985. Hydrogeological and hydrogeochemical investigations in boreholes - final report of the phase 1 geochemical investigations of the Stripa ground waters. SKB Technical Report 85-06. Swedish Nuclear Fuel and Waste Management Co., Box 5864, S-102 48 Stockholm.
- Olsen, G. J., D. J. Lane, S. J. Giovannoni, and N. R. Pace. 1986. Microbial ecology and evolution : A ribosomal RNA approach. *Annual Review of Microbiology* 40:337-365.
- Olsen, G. J., N. Larsen, and C. R. Woese. 1991. The ribosomal RNA Database project. *Nucleic Acids Research*. 19:2017-2021.
- Pace, N. R., D. A. Stahl, D. J. Lane, and G. J. Olsen. 1986. The analysis of natural microbial populations by ribosomal RNA sequence. *Advances in Microbial Ecology* 9:1-55.
- Pedersen, K. 1982. Method for studying microbial biofilms in flowing-water systems. *Applied and Environmental Microbiology* 43:6-13.
- Pedersen, K. (1988). Preliminary investigations of deep ground water microbiology in Swedish granitic rock. *SKB Technical Report 88-01*. Swedish Nuclear Fuel and Waste Management Co., Box 5864, S-102 48 Stockholm.
- Pedersen, K. 1993a. The deep subterranean biosphere. *Journal of Earth Science Reviews* 34:243-360
- Pedersen, K. 1993b. Bacterial processes in nuclear waste disposal. *Microbiology Europe* 1(2):18-23
- Pedersen, K., and Y. Albinsson. 1991. Effect of cell number, pH and lanthanide concentration on the sorption of promethium by *Shewanella putrefaciens*. *Radiochimica Acta*. 54:91-95.

- Pedersen, K., and Y. Albinsson. 1992. Possible effects of bacteria on trace element migration in crystalline bed-rock. *Radiochimica Acta*, 58/59:365-369.
- Pedersen, K., and S. Ekendahl. 1990. Distribution and activity of bacteria in deep granitic groundwaters of southeastern Sweden. *Microbial Ecology* 20:37-52.
- Pedersen, K., and S. Ekendahl. 1992a. Incorporation of CO<sub>2</sub> and introduced organic compounds by bacterial populations in groundwater from the deep crystalline bedrock of the Stripa mine. *Journal of General Microbiology* 138:369-376.
- Pedersen, K., and S. Ekendahl. 1992b. Assimilation of CO<sub>2</sub> and introduced organic compounds by bacterial communities in groundwater from Southeastern Sweden deep crystalline bedrock. *Microbial Ecology* 23:1-14.
- Pedersen, K., S. Ekendahl, and J. Arlinger. 1991. Microbes in crystalline bedrock: Assimilation of CO<sub>2</sub> and introduced organic compounds by bacterial populations in groundwater from deep crystalline bedrock at Laxemar and Stripa. SKB technical report 91-56, Swedish nuclear fuel and waste management Co., Box 5864, S-102 48 Stockholm, Sweden, 53 pp.
- Pedersen, K., C. Holmström, A.-K. Olsson, and A. Pedersen. 1986. Statistic evaluation of the influence of species variation, culture conditions, surface wettability and fluid shear on attachment and biofilm development of marine bacteria. *Archives of Microbiology* 145:1-8.
- Pettersson, C., J. Ephraim, B. Allard, and H. Borén. 1990. Characterization of humic substances from deep ground waters in granitic bedrock in Sweden. SKB Technical Report 90-29. Swedish Nuclear Fuel and Waste Management Co., Box 5864, S-102 48 Stockholm.
- Prescott, L. M., J. P. Harley, and D. A. Klein. 1993. The use of energy in biosynthesis, p. 171-190. In *Microbiology*, 2nd ed. Wm. C. Brown Publishers, Dubuque, Iowa.
- Shuttleworth, K. L., and R. F. Unz. 1993. Sorption of heavy metals to the filamentous bacterium *Thiothrix* strain A1. *Applied and Environmental Microbiology* 59:1274-1282.
- SKB 1991. SKB Annual report 1991. Including summaries of technical reports issued during 1991. SKB technical report 91-64, Swedish nuclear fuel and waste management Co., Box 5864, S-102 48 Stockholm, Sweden, 195 pp.
- Stackebrandt, E. and M. Goodfellow. 1991. Nucleic acid techniques in bacterial systematics, p. 329. John Wiley & Sons, Chichester.
- Stanier, R.Y., J. L. Ingraham, M. L. Wheelis, and P. R. Painter. 1990. *General microbiology*, 5th ed. London: MacMillan Education Ltd.
- Steffan, R.J. and R.M. Atlas. 1991. Polymerase chain reaction. Applications in environmental microbiology. *Annual Review of Microbiology* 45:137-61.

- Stevens, T. O., J. P. McKinley, and J. K. Fredrickson. 1993. Bacteria associated with deep, alkaline, anaerobic groundwaters in southeast Washington. *Microbial Ecology* 25:35-50.
- Strandberg, G.W., E. Starling, I. Shumate, and J.R. Parrot. 1981. Microbial cells as biosorbents for heavy metals: Accumulation of uranium by *Saccharomyces cerevisiae* and *Pseudomonas aeruginosa*. *Applied and Environmental Microbiology*. 41:237-245.
- Wallace, D. M. 1987. Large and small scale phenol extractions. *Methods in Enzymology* 152.
- Ward, D.M., M.M. Bateson, R. Weller, and A.L. Ruff-Roberts. 1992. Ribosomal RNA analysis of microorganisms as they occur in nature., p. 219-286. In K.C. Marshall (ed.), *Advances in microbial ecology.*, vol. 12. Plenum Press, New York.
- Weller, R. and D. Ward. 1989. Selective recovery of 16S rRNA sequences from natural microbial communities in the form of cDNA. *Applied and Environmental Microbiology*. 55:1818-1822.
- West, J. M., N. Christofi, and I. G. McKinley. 1982. Microbes in deep geological systems and their possible influence on radioactive waste disposal. *Radioactive Waste Management Nuclear Fuel Cycle* 3:1-15.
- West, J.M., N. Christofi, and I. G. McKinley. 1985. An overview of recent microbiological research relevant to the geological disposal of nuclear waste. *Radioactive Waste Management and the Nuclear Fuel Cycle* 6:79-95.
- White, D.C., G.A. Smith, M.J. Gehron, J.H. Parker, R.H. Findlay, R.F. Martz, and H.L. Fredrickson. 1983. The groundwater aquifer microbiota: Biomass, community structure, and nutritional status. *Developmental and Industrial Microbiology* 24:201-211.
- Woese, C.R. 1987. Bacterial evolution. *Microbiological Reviews* 51:221-271.



# List of SKB reports

## Annual Reports

1977-78

TR 121

### **KBS Technical Reports 1 – 120**

Summaries

Stockholm, May 1979

1979

TR 79-28

### **The KBS Annual Report 1979**

KBS Technical Reports 79-01 – 79-27

Summaries

Stockholm, March 1980

1980

TR 80-26

### **The KBS Annual Report 1980**

KBS Technical Reports 80-01 – 80-25

Summaries

Stockholm, March 1981

1981

TR 81-17

### **The KBS Annual Report 1981**

KBS Technical Reports 81-01 – 81-16

Summaries

Stockholm, April 1982

1982

TR 82-28

### **The KBS Annual Report 1982**

KBS Technical Reports 82-01 – 82-27

Summaries

Stockholm, July 1983

1983

TR 83-77

### **The KBS Annual Report 1983**

KBS Technical Reports 83-01 – 83-76

Summaries

Stockholm, June 1984

1984

TR 85-01

### **Annual Research and Development Report 1984**

Including Summaries of Technical Reports Issued during 1984. (Technical Reports 84-01 – 84-19)

Stockholm, June 1985

1985

TR 85-20

### **Annual Research and Development Report 1985**

Including Summaries of Technical Reports Issued during 1985. (Technical Reports 85-01 – 85-19)

Stockholm, May 1986

1986

TR 86-31

### **SKB Annual Report 1986**

Including Summaries of Technical Reports Issued during 1986

Stockholm, May 1987

1987

TR 87-33

### **SKB Annual Report 1987**

Including Summaries of Technical Reports Issued during 1987

Stockholm, May 1988

1988

TR 88-32

### **SKB Annual Report 1988**

Including Summaries of Technical Reports Issued during 1988

Stockholm, May 1989

1989

TR 89-40

### **SKB Annual Report 1989**

Including Summaries of Technical Reports Issued during 1989

Stockholm, May 1990

1990

TR 90-46

### **SKB Annual Report 1990**

Including Summaries of Technical Reports Issued during 1990

Stockholm, May 1991

1991

TR 91-64

### **SKB Annual Report 1991**

Including Summaries of Technical Reports Issued during 1991

Stockholm, April 1992

1992

TR 92-46

### **SKB Annual Report 1992**

Including Summaries of Technical Reports Issued during 1992

Stockholm, May 1993

## Technical Reports

### List of SKB Technical Reports 1993

TR 93-01

#### **Stress redistribution and void growth in butt-welded canisters for spent nuclear fuel**

B L Josefson<sup>1</sup>, L Karlsson<sup>2</sup>, H-Å Häggblad<sup>2</sup>

<sup>1</sup> Division of Solid Mechanics, Chalmers University of Technology, Göteborg, Sweden

<sup>2</sup> Division of Computer Aided Design, Luleå University of Technology, Luleå, Sweden

February 1993

TR 93-02

#### **Hydrothermal field test with French candidate clay embedding steel heater in the Stripa mine**

R Pusch<sup>1</sup>, O Karnland<sup>1</sup>, A Lajudie<sup>2</sup>, J Lechelle<sup>2</sup>, A Bouchet<sup>3</sup>

<sup>1</sup> Clay Technology AB, Sweden

<sup>2</sup> CEA, France

<sup>3</sup> Etude Recherche Materiaux (ERM), France

December 1992

TR 93-03

#### **MX 80 clay exposed to high temperatures and gamma radiation**

R Pusch<sup>1</sup>, O Karnland<sup>1</sup>, A Lajudie<sup>2</sup>, A Decarreau<sup>3</sup>,

<sup>1</sup> Clay Technology AB, Sweden

<sup>2</sup> CEA, France

<sup>3</sup> Univ. de Poitiers, France

December 1992

TR 93-04

#### **Project on Alternative Systems Study (PASS).**

##### **Final report**

October 1992

TR 93-05

#### **Studies of natural analogues and geological systems.**

##### **Their importance to performance assessment**

Fredrik Brandberg<sup>1</sup>, Bertil Grundfelt<sup>1</sup>, Lars Olof Höglund<sup>1</sup>, Fred Karlsson<sup>2</sup>,

Kristina Skagius<sup>1</sup>, John Smellie<sup>3</sup>

<sup>1</sup> KEMAKTA Konsult AB

<sup>2</sup> SKB

<sup>3</sup> Conterra AB

April 1993

TR 93-06

#### **Mineralogy, geochemistry and petrophysics of red coloured granite adjacent to fractures**

Thomas Eliasson

Chalmers University of Technology and University of Göteborg, Department of Geology, Göteborg, Sweden

March 1993

TR 93-07

#### **Modelling the redox front movement in a KBS-3 nuclear waste repository**

L Romero, L Moreno, I Neretnieks

Department of Chemical Engineering,

Royal Institute of Technology, Stockholm, Sweden

May 1993

TR 93-08

#### **Äspö Hard Rock Laboratory Annual Report 1992**

SKB

April 1993

TR 93-09

#### **Verification of the geostatistical inference code INFERENS, Version 1.1, and demonstration using data from Finnsjön**

Joel Geier

Golder Geosystem AB, Uppsala

June 1993

TR 93-10

#### **Mechanisms and consequences of creep in the nearfield rock of a KBS-3 repository**

Roland Pusch, Harald Hökmark

Clay Technology AB, Lund, Sweden

December 1992

TR 93-11

#### **Post-glacial faulting in the Lansjärv area, Northern Sweden.**

##### **Comments from the expert group on a field visit at the Molberget post-glacial fault area, 1991**

Roy Stanfors (ed.)<sup>1</sup>, Lars O Ericsson (ed.)<sup>2</sup>

<sup>1</sup> R S Consulting AB

<sup>2</sup> SKB

May 1993

TR 93-12

#### **Possible strategies for geoscientific classification for high-level waste repository site selection**

Lars Rosén, Gunnar Gustafson

Department of Geology, Chalmers University of Technology and University of Göteborg

June 1993

TR 93-13

#### **A review of the seismotectonics of Sweden**

Robert Muir Wood

EQE International Ltd, Warrington, Cheshire, England

April 1993

TR 93-14

**Simulation of the European ice sheet trough the last glacial cycle and prediction of future glaciation**

G S Boulton, A Payne

Department of Geology and Geophysics,  
Edinburgh University, Grant Institute, Edinburgh,  
United Kingdom

December 1992

TR 93-21

**Development of "CHEMFRONTS", a coupled transport and geochemical program to handle reaction fronts**

Catharina Bäverman

Department of Chemical Engineering, Royal Institute  
of Technology, Stockholm, Sweden

October 1993

TR 93-15

**Analysis of the regional groundwater flow in the Finnsjön area**

Anders Boghammar, Bertil Grundfelt, Hans Widén

Kemakta Konsult AB

June 1993

TR 93-16

**Kinetic modelling of bentonite - canister interaction. Implications for Cu, Fe, and Pb corrosion in a repository for spent nuclear fuel**

Paul Wersin, Jordi Bruno, Kastriot Spahiu

MBT Tecnologia Ambiental, Cerdanyola, Spain

June 1993

TR 93-17

**Oxidation of uraninite**

Janusz Janeczek, Rodney C Ewing

Department of Earth & Planetary Science, University  
of New Mexico, Albuquerque, NM, USA

June 1993

TR 93-18

**Solubility of the redox-sensitive radionuclides <sup>99</sup>Tc and <sup>237</sup>Np under reducing conditions in neutral to alkaline solutions. Effect of carbonate**

Trygve E Eriksen<sup>1</sup>, Pierre Ndalamba<sup>1</sup>, Daqing Cui<sup>1</sup>,  
Jordi Bruno<sup>2</sup>, Marco Caceci<sup>2</sup>, Kastriot Spahiu<sup>2</sup>

<sup>1</sup> Dept. of Nuclear Chemistry, Royal Institute of  
Technology, Stockholm, Sweden

<sup>2</sup> MBT Tecnologia Ambiental, Cerdanyola, Spain

September 1993

TR 93-19

**Mechanical properties of fracture zones**

Bengt Leijon

Conterra AB

May 1993

TR 93-20

**The Fracture Zone Project - Final report**

Peter Andersson (ed.)

Geosigma AB, Uppsala, Sweden

September 1993